

CAUTION



To prevent serious personal injury and/or property damage, operate all rKITtely controlled models in a responsible manner as outlined herein.

◆ **Safety Precautions**

- 1.1 This radio-controlled model is not a toy, it is designed for persons 14 years of age or older.
- 1.2 Do not operate your vehicle on unsafe terrain; always pay attention to your surroundings.
- 1.3 Never operate your vehicle on public roadways, around moving people, animals, or operating machinery.
- 1.4 Keep clear of power lines and high-powered radio equipment to minimize radio frequency interference.
- 1.5 Since this vehicle contains small components, it may be a choking hazard for small children. Keep the vehicle and any spare parts out of reach of small children.

◆ **Inspect your radio-controlled model before operation**

- 2.1 Ensure that all screws are properly tightened. Use thread-lock to secure any metal to metal contacts- especially for components designed to withstand torque (servo mounts, motor mount, drive shaft grub screws etc.).
- 2.2 Always check the battery voltage for both the transmitter and vehicle prior to operating your vehicle. Keep the batteries fresh in the transmitter and always begin your vehicle runs with a fully charged battery pack.
- 2.3 Always check that the motor and servo are operating smoothly and in the right direction prior to operation. If binding between components is observed, replace parts as necessary to reduce possibility of component or servo damage.
- 2.4 To turn on your vehicle, always power on your transmitter first, then power on your receiver.

◆ **After operating your radio-controlled model**

- 3.1 To turn off the vehicle, always power off your receiver prior to powering off your transmitter.
- 3.2 Use caution when handling the vehicle- components, especially the ESC and motor which will be hot after operation.
- 3.3 Never use battery packs which are dented or otherwise damaged. Ensure that the wire insulation is intact and that connectors are properly soldered. Lithium batteries can become fire hazards if mishandled.

TOOLS

(Not included)

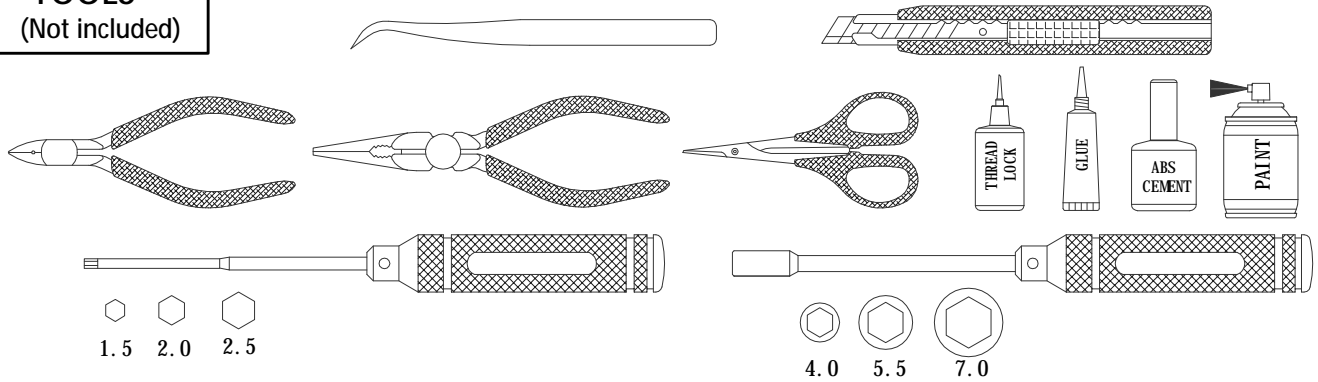

Installation Reminder

1. Please read the manual carefully before installation.
2. The Electronic equipment to be purchased separately:
 - (1) . 4 channels or above transmission and receiver * 1;
 - (2) .Steering servo * 1;
 - (3) . 25g Micro servo *2;
 - (4) . ESC * 1;
 - (5) . Battery (size in 150 * 50 * 40 mm).
3. Motor gear range: M0.6, 10t-18T.
4. Application range: Brush motor 30t - 35t; Brushless motor 1400kV.
5. Screw sealant is only used between screw and metal parts.
6. Please don't install tires or leave the model above the ground When debugging the truck.
7. Please clean the surface first before paint to truck body. Keep it in a ventilated and safe environment and away from the fire source.

Electronic equipment

(Not included)

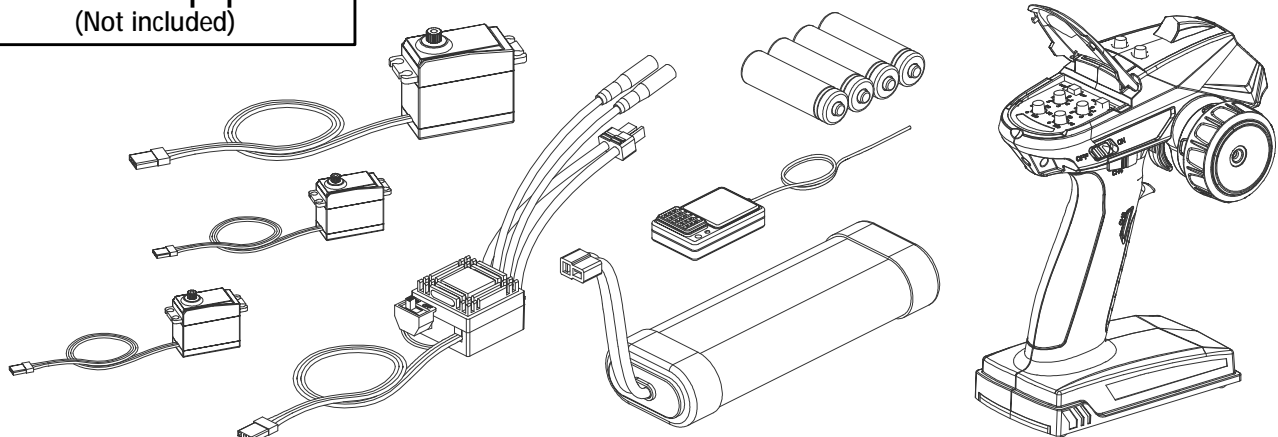

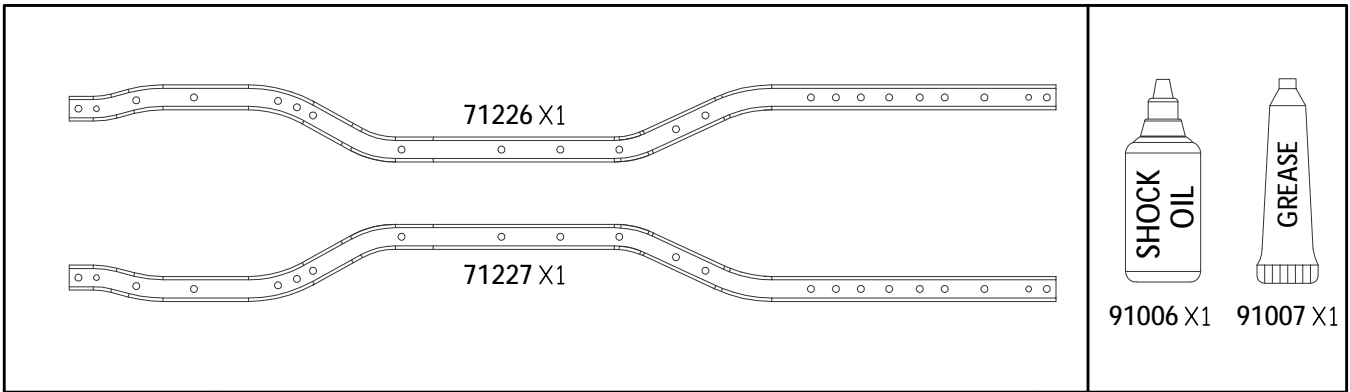

BAG(A)

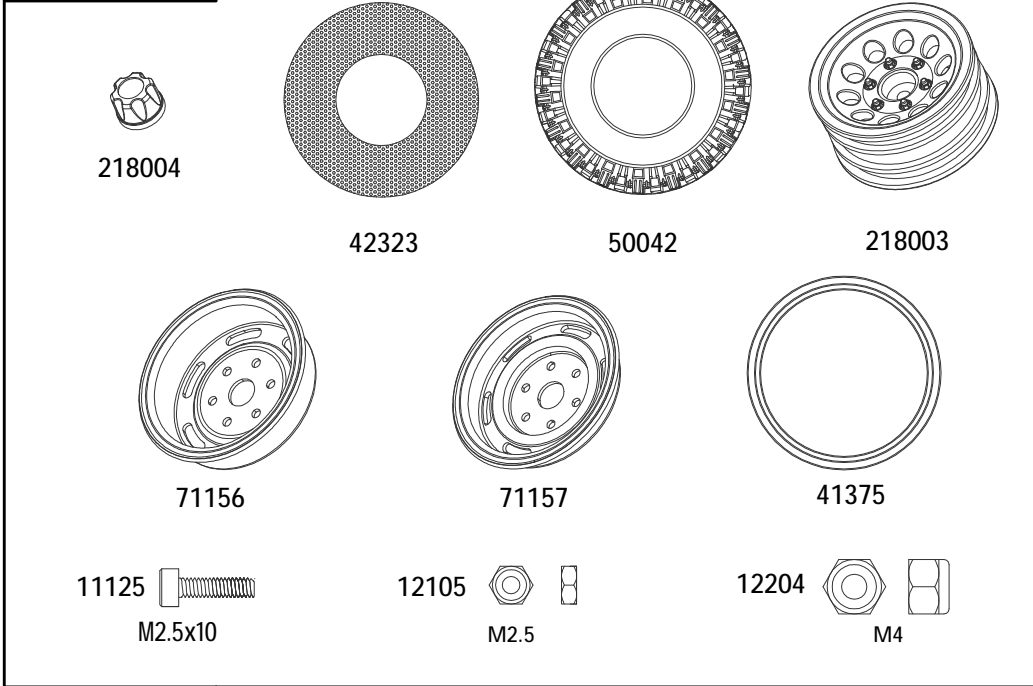

AT4(KIT)	
1	71156 X4
2	71157 X4
3	30307 X4
4	41375 X4
5	11125 X24
6	12105 X24
7	12204 X4
AT4(RTR)	
1	218003 X4
2	218004 X4
3	50042 X4
4	42323 X4
5	12204 X4

BAG(B)

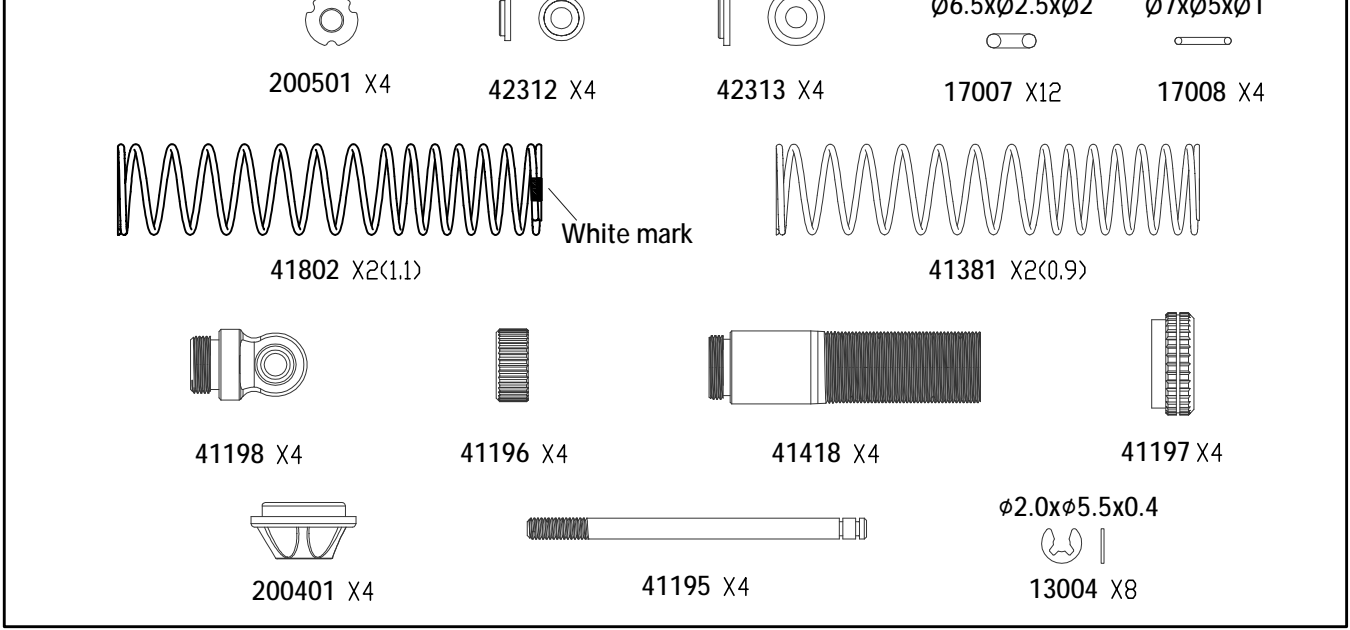

AT4(KIT)/(RTR)

BAG(C)

AT4(KIT)/(RTR)

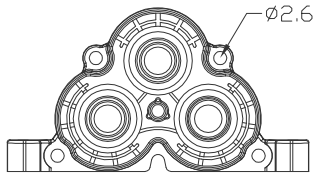

215205

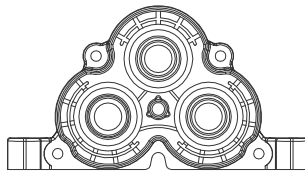

215206

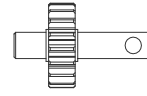

41556 (18T)X3



15012

φ5xφ10x4 X6



72026

φ5xφ8x0.2 X6

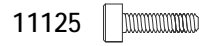

11125

M2.5x10 X4

BAG(D)

AT4(KIT)/(RTR)

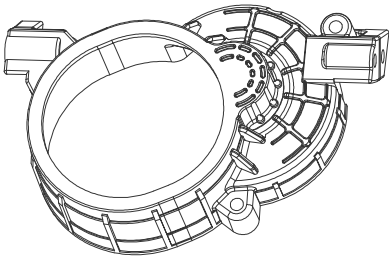

215202

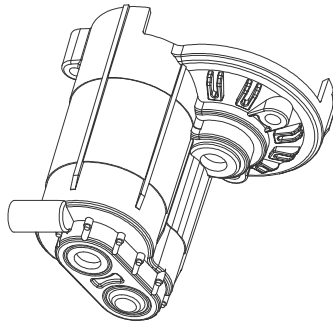

215203

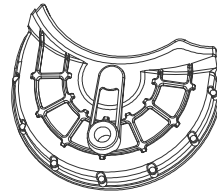

215201

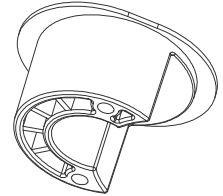

215204

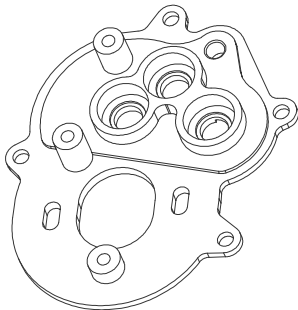

33801

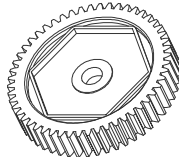

215101(52T)

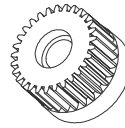

33901(29T)

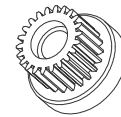

33902(22T)

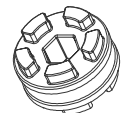

33903

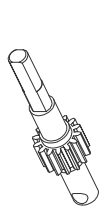

41549(14T)



41302(10T)

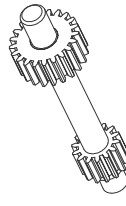

41550 (21T-14T)

13001



φ3xφ7.2x0.5 X2



41554



41307

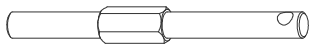

42201

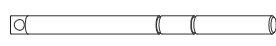

42202

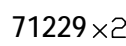

71229 x2

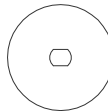

15012

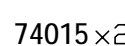

74015 x2

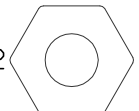

15014

14201



φ4.2xφ8x0.4 X4

42203



φ5.1xφ8x1.5 X3

72003



φ5xφ8x0.5 X1

72026



φ5xφ8x0.2 X1

15012



φ5xφ10x4 X6

15014



φ5xφ8x2.5 X4

11401



M3x4 X1

11207



M3x10 X7

11114

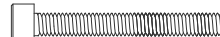

M3x25 X2

12304

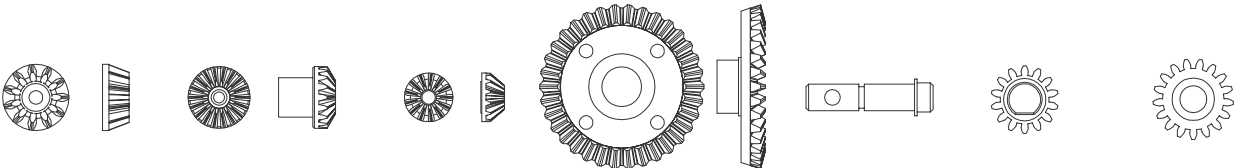
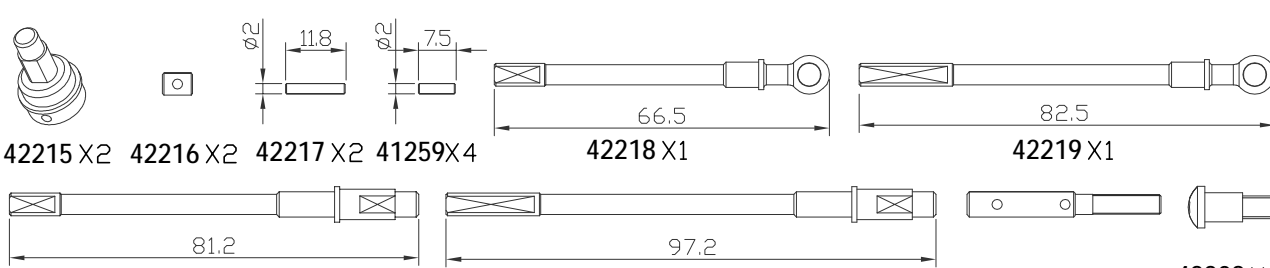
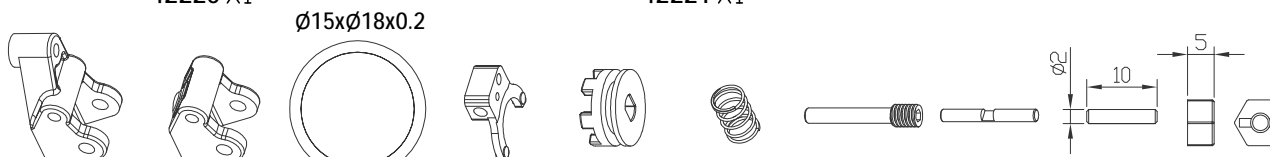
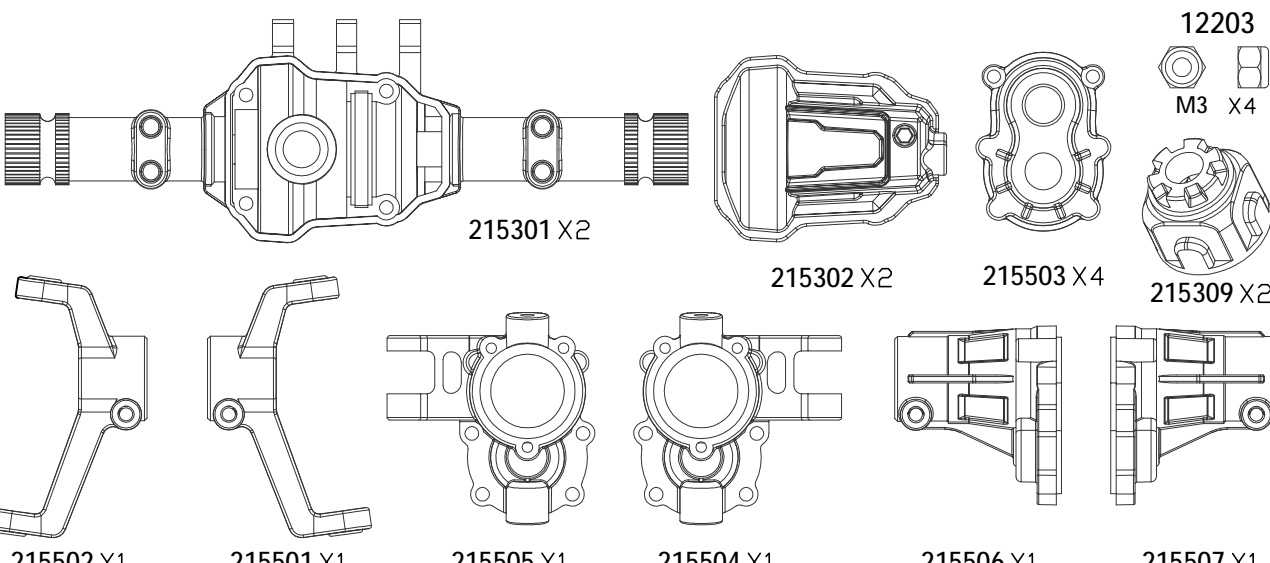
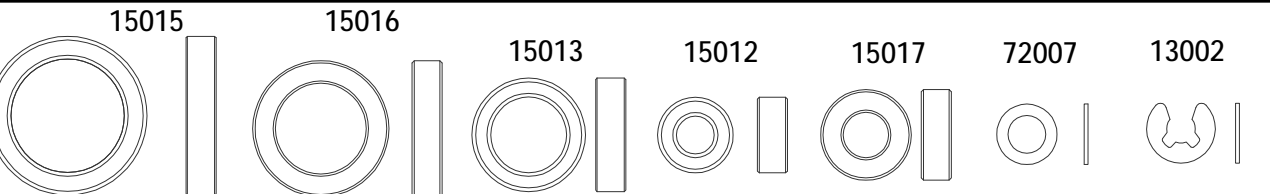
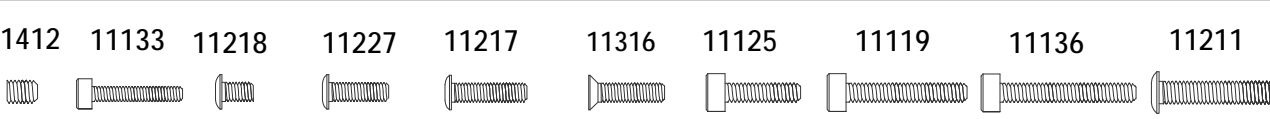

M4 X1

BAG(E)	AT4(KIT)/(RTR)								
 <p>33905(11T) X2 33906(18T) X4 33907(13T) X8 33904(34T) X2 42214 X2 34701(14T) X4 34702(17T) X4</p>									
 <p>42215 X2 42216 X2 42217 X2 41259 X4 42218 X1 42219 X1 42220 X1 42221 X1 42222 X4 42208 X4</p> <p style="text-align: center;">$\phi 15 \times \phi 18 \times 0.2$</p>  <p>215307 X1 215308 X3 75020 X2 41558 X2 33908 X2 41398 X2 42209 X2 42223 X4 41209 X4 44092 X4</p>									
 <p>215301 X2 215302 X2 215503 X4 12203 M3 X4 215309 X2 215502 X1 215501 X1 215505 X1 215504 X1 215506 X1 215507 X1</p>									
 <p>15015 15016 15013 15012 15017 72007 13002</p> <p>$\phi 15 \times \phi 21 \times 4$ X2 $\phi 12 \times \phi 18 \times 4$ X2 $\phi 10 \times \phi 15 \times 4$ X2 $\phi 5 \times \phi 10 \times 4$ X10 $\phi 6 \times \phi 12 \times 4$ X2 $\phi 5 \times \phi 8 \times 0.3$ X2 $\phi 3.8 \times \phi 9.2 \times 0.6$ X2</p>									
 <p>11412 11133 11218 11227 11217 11316 11125 11119 11136 11211</p> <p>M3x3 X6 M2x12 X4 M2.5x4 X6 M2.5x8 X8 M2.5x10 X24 M2.5x10 X2 M2.5x10 X8 M2.5x16 X2 M2.5x18 X8 M3x18 X4</p>									

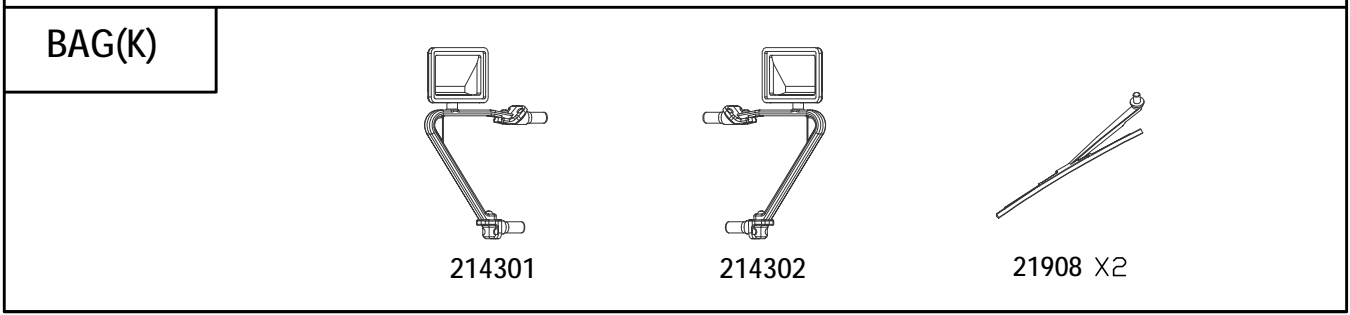
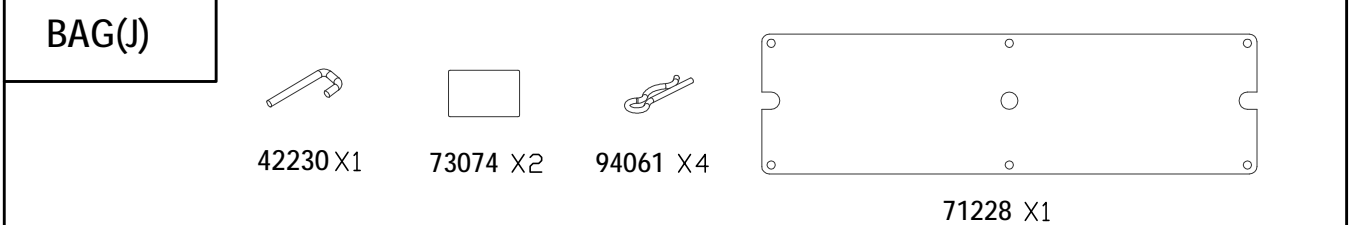
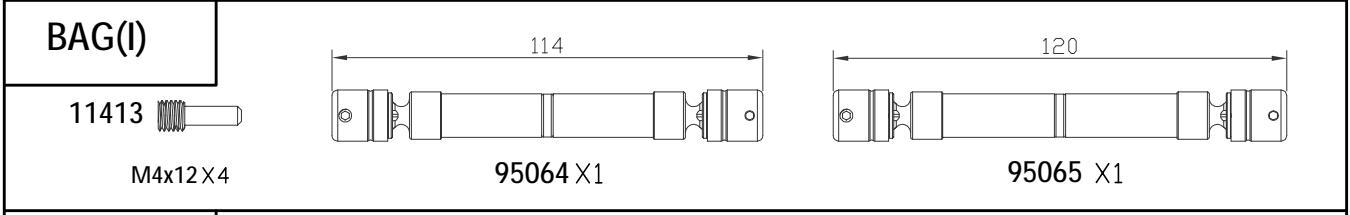
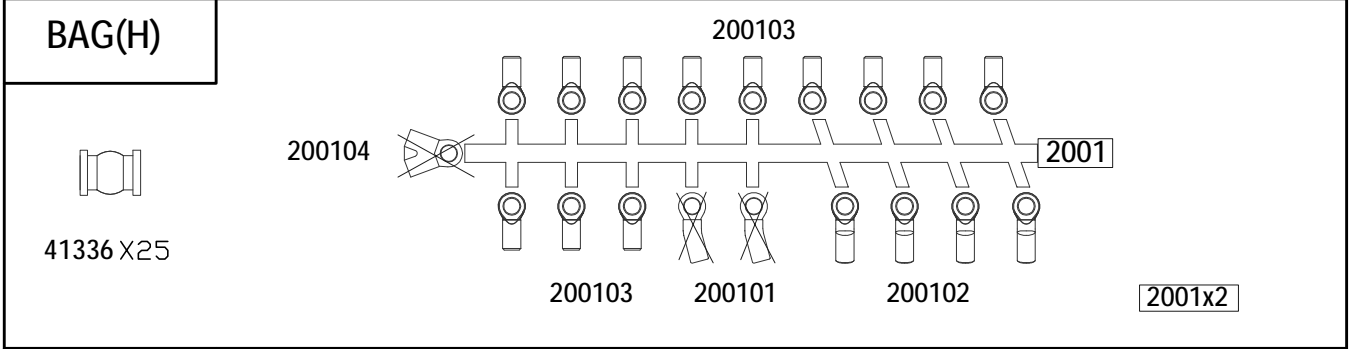
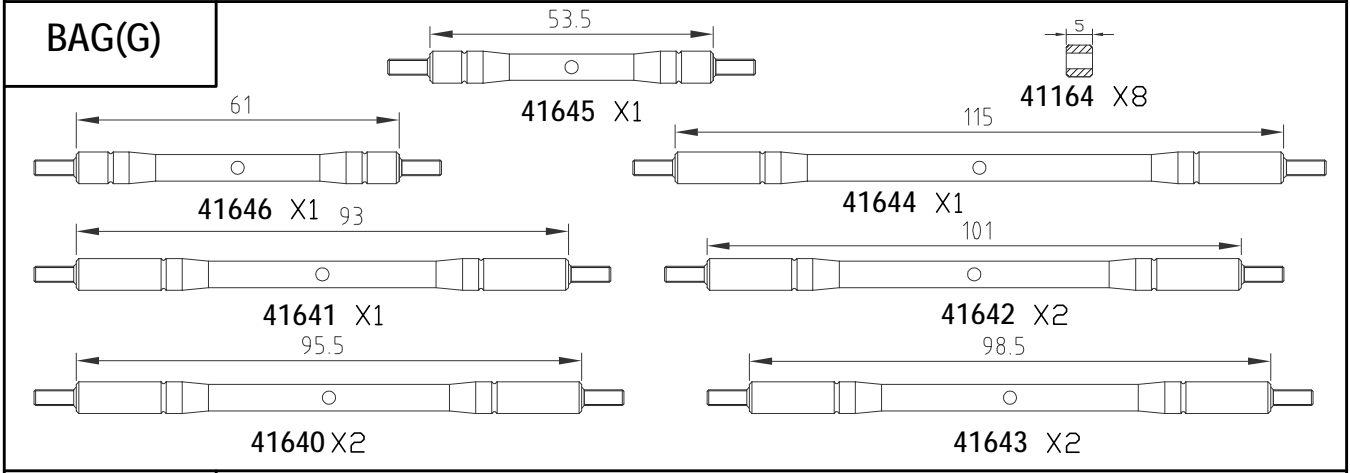
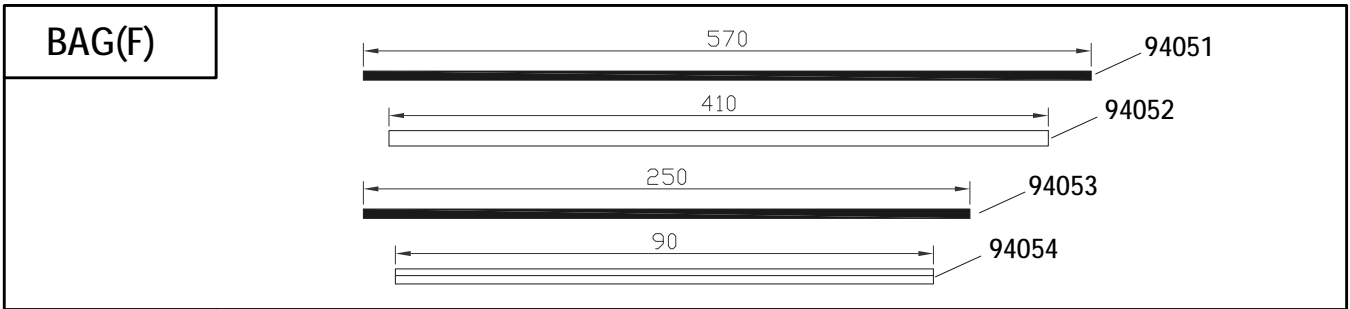

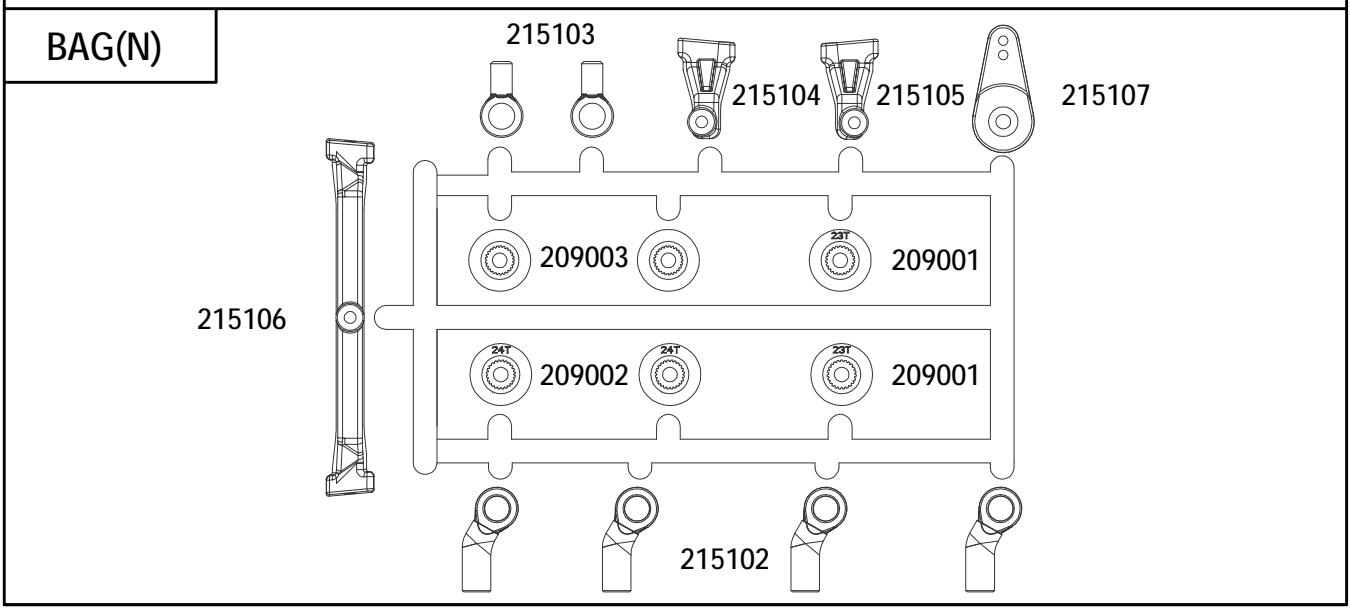
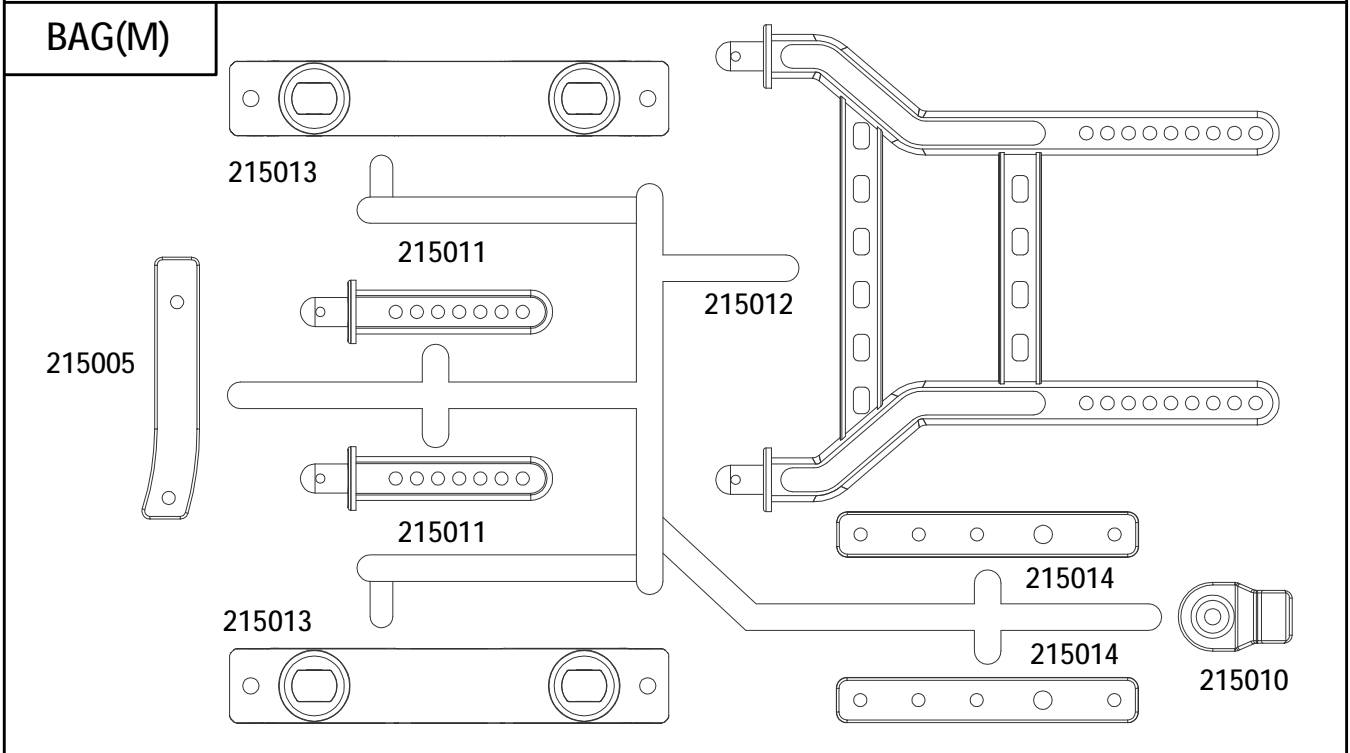
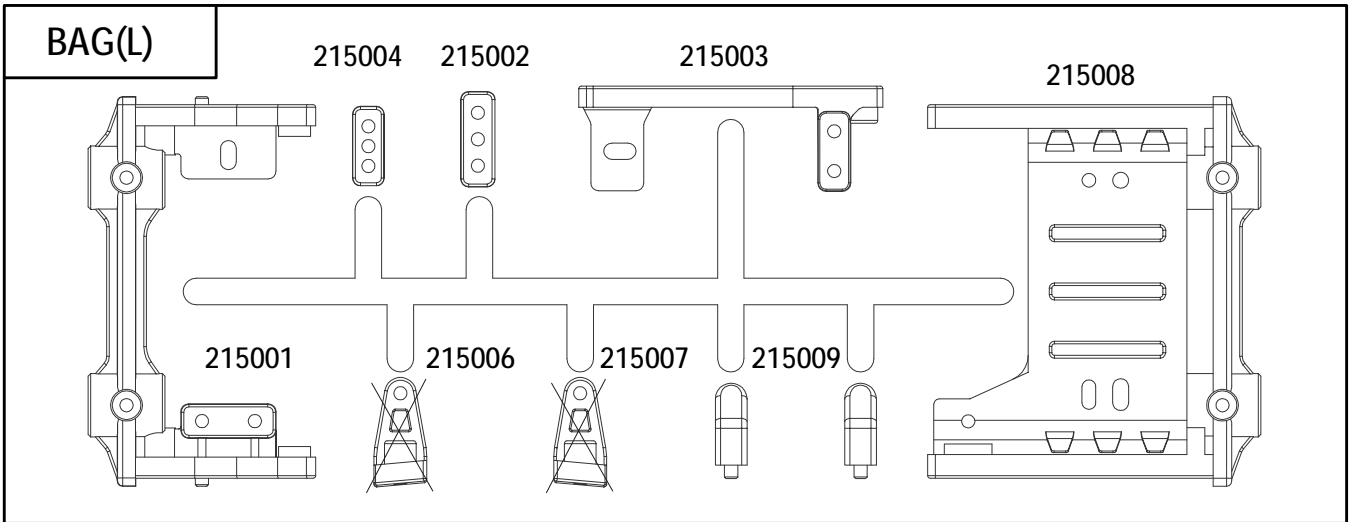

BAG(O)

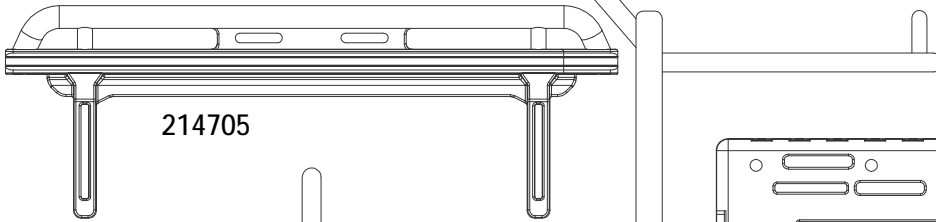
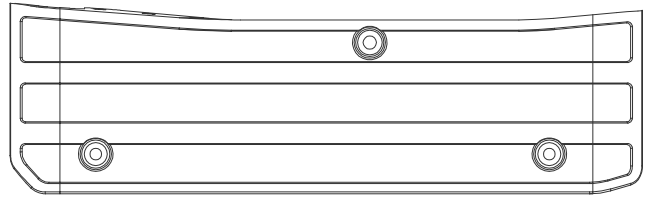
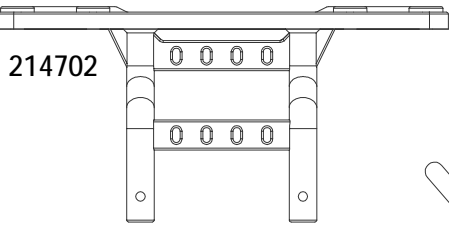

214707

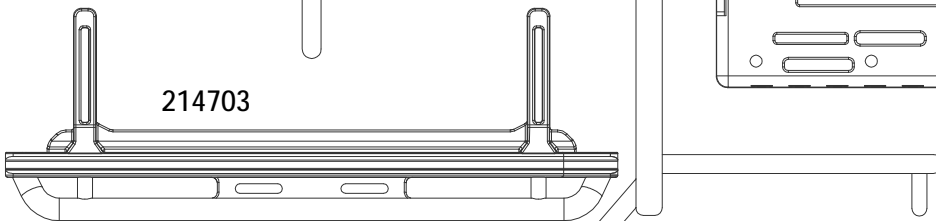
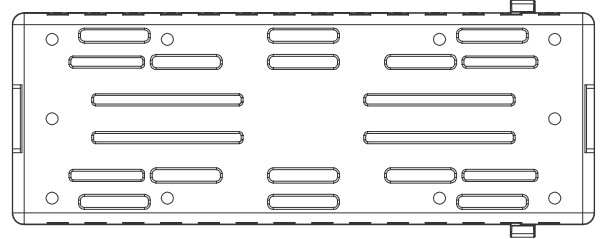

214706

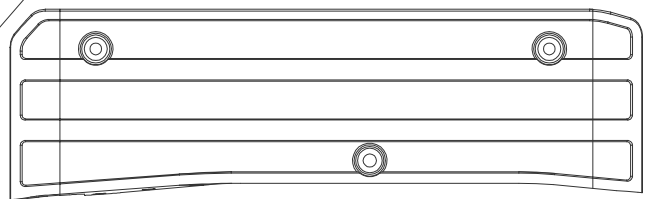

BAG(P)

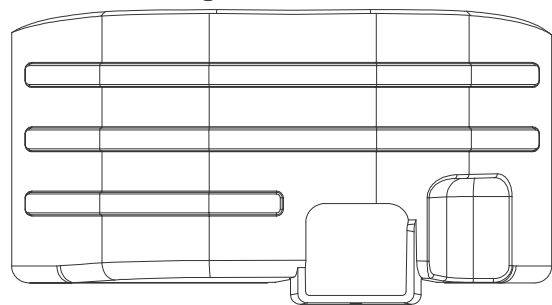
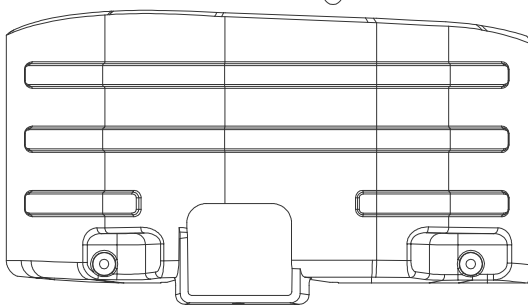
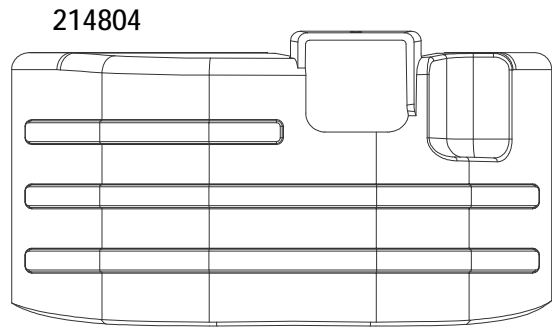
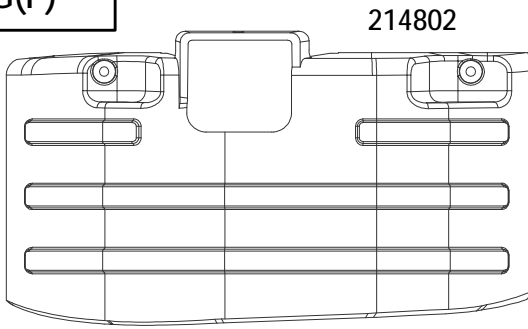

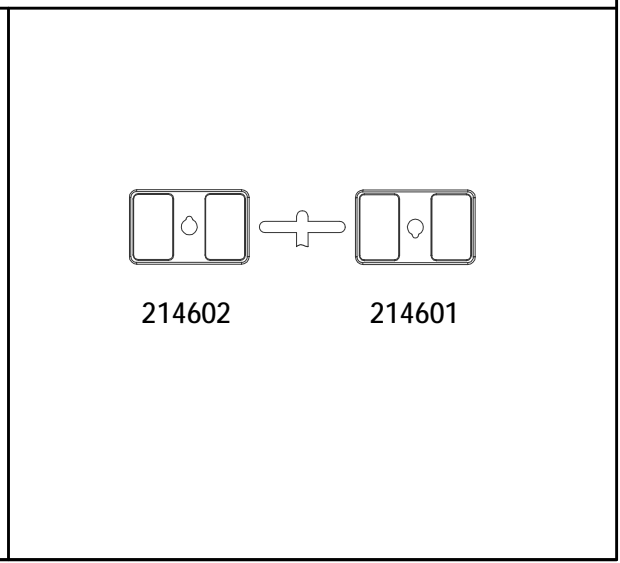
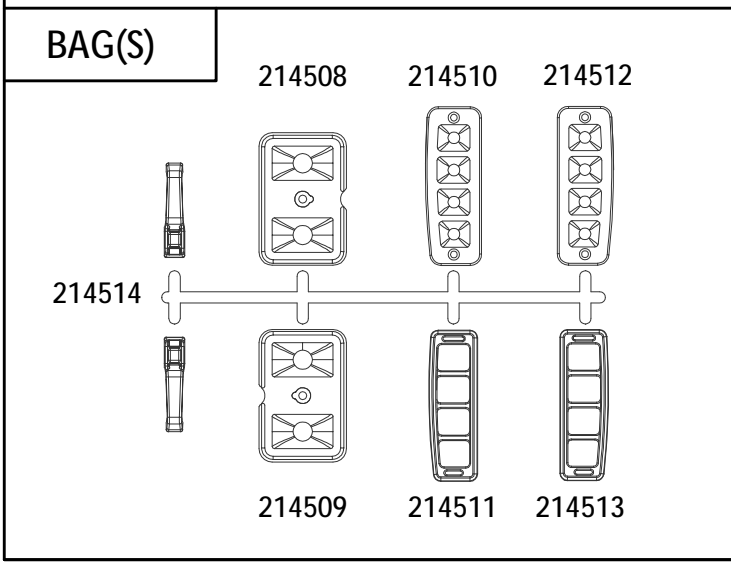
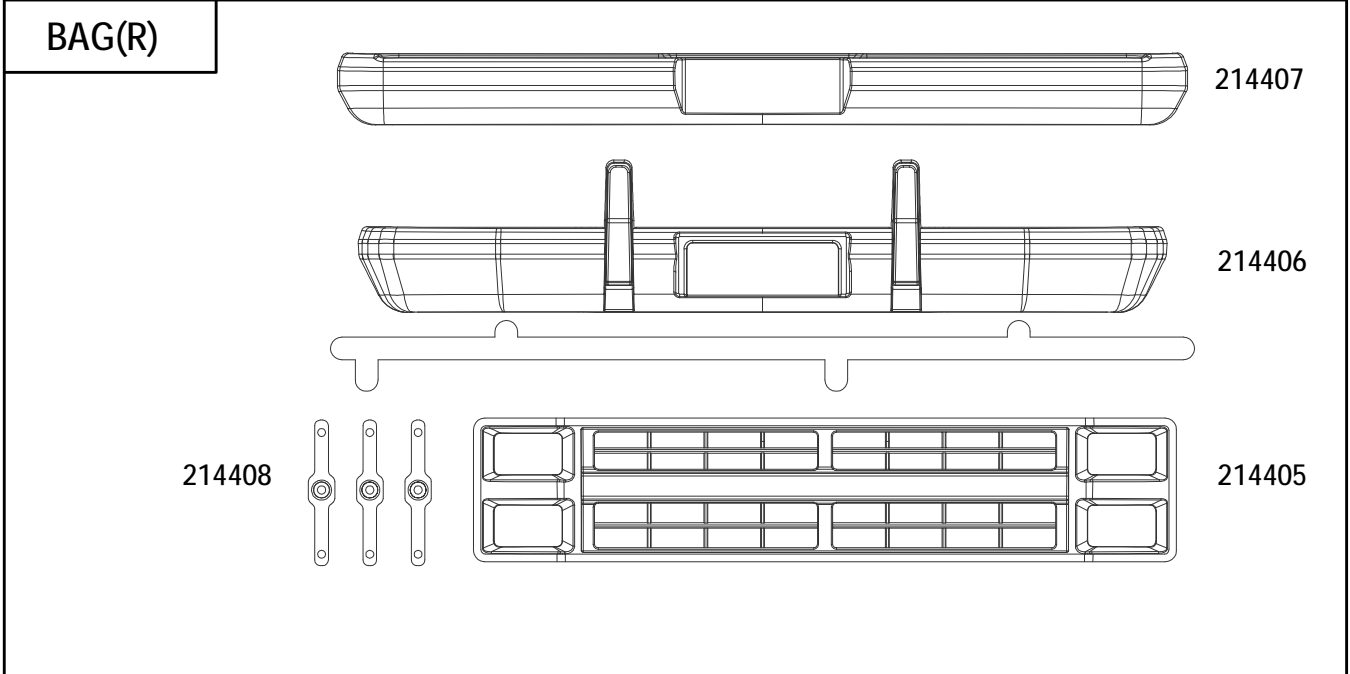
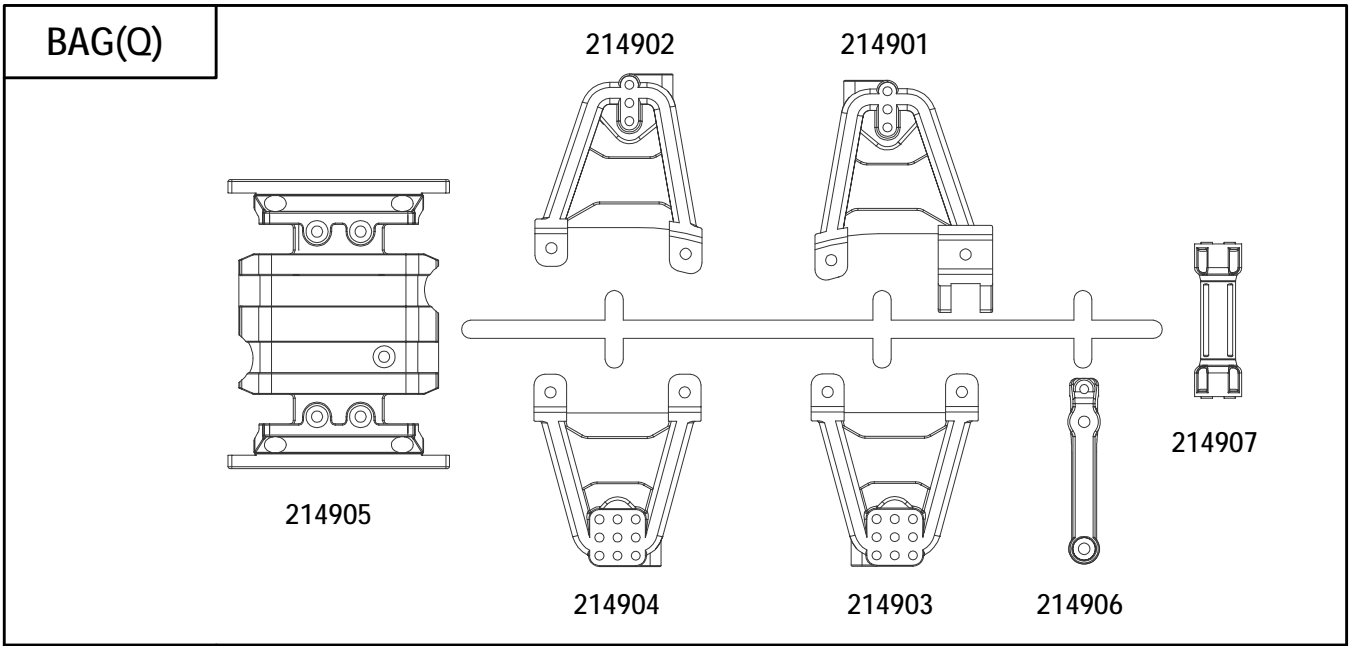



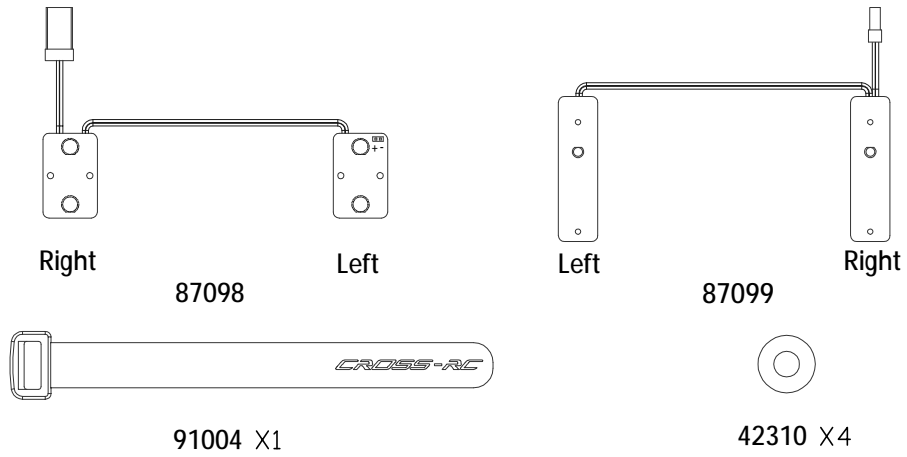



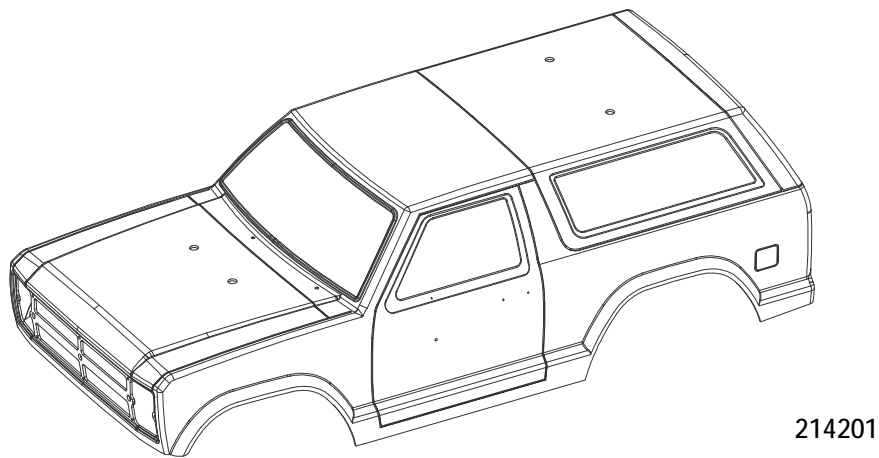

















BAG(T)



BAG(U)



BAG(V)

11205  M3x6 X3	11102  M2x6 X6	11303  M3x8 X12	12203  M3 X10
11206  M3x8 X17	11106  M3x8 X1	11413  M4x12 X4	42224  Ø3x10 .8 X2
11207  M3x10 X15	11107  M3x10 X29	11704  M1.6x6 X4	41629  Ø1.5xØ1 x20 X2
11209  M3x14 X5	11111  M3x18 X3	11401  M3x4 X2	91152  Ø4xØ3 X2
11210  M3x16 X4	11112  M3x20 X8	11214  M3x25 X5	14102  Ø3xØ7x0.5 X1
11211  M3x18 X4	11116  M2.5x12 X2	11215  M3x28 X2	

AT4(KIT)/(RTR)

1

BAG(D)

15012



∅5x∅10x4 X1

12304

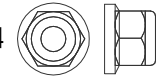

M4 X1

14201



∅4.2x∅8x0.4 X4

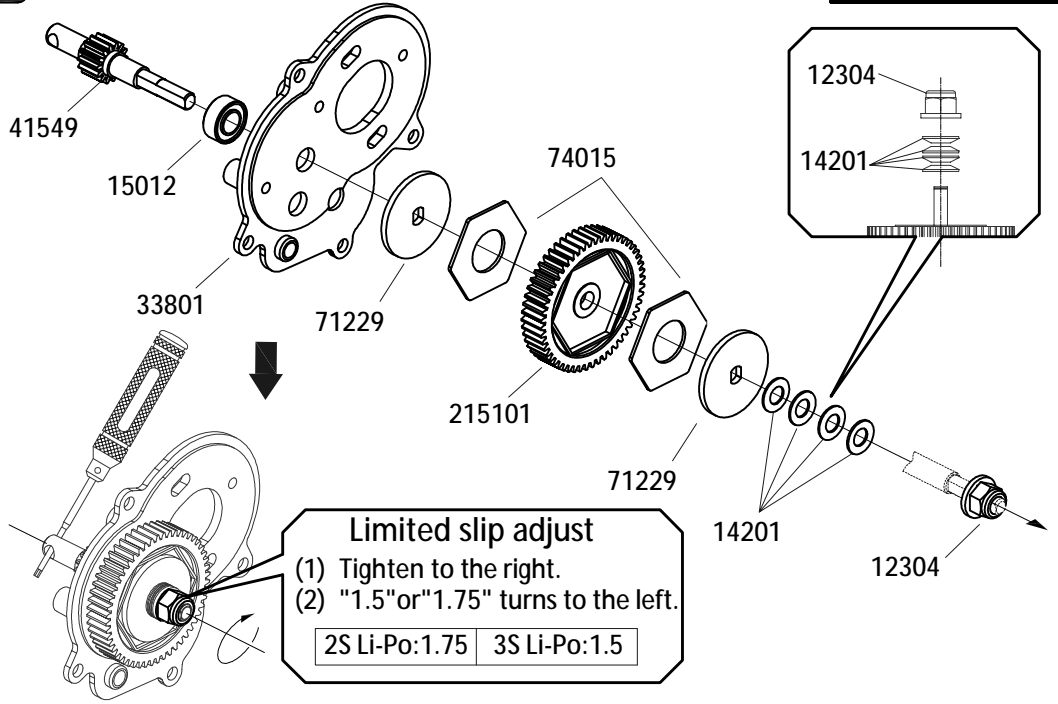

Limited slip adjust
 (1) Tighten to the right.
 (2) "1.5" or "1.75" turns to the left.
 2S Li-Po: 1.75 3S Li-Po: 1.5

2

AT4(KIT)/(RTR)

11401



M3x4 X1

11207



M3x10 X3

11114

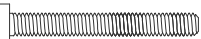

M3x25 X2

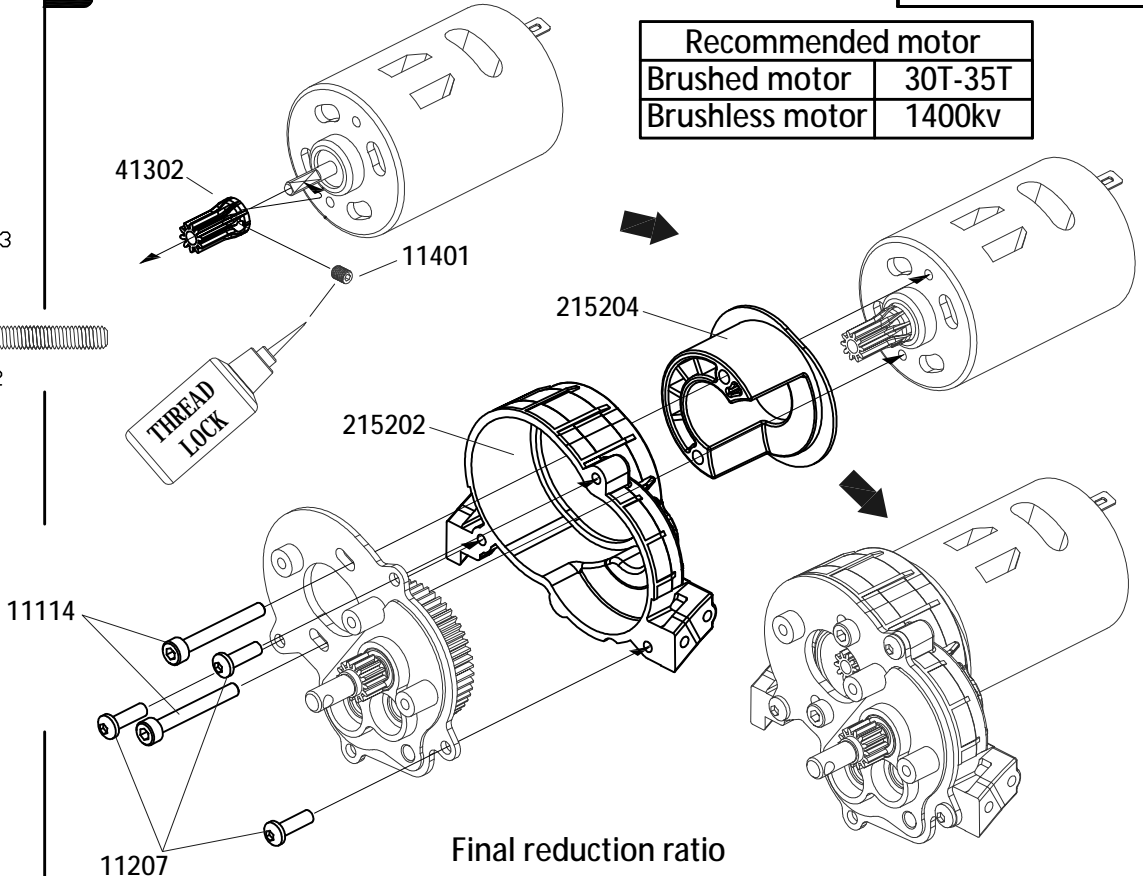

Recommended motor	
Brushed motor	30T-35T
Brushless motor	1400kv

Final reduction ratio

Motor gear	10T	11T	12T	13T	14T	15T	16T	17T	18T
Fast	30.2	27.5	25.2	23.2	21.6	20.1	18.9	17.8	16.8
Slow	59.7	54.3	49.8	45.9	42.6	39.8	37.3	35.1	33.2

AT4(KIT)/(RTR)

3

BAG(D)

15014



∅5x∅8x2.5 X4

13001



∅3x∅7.8x0.5 X2

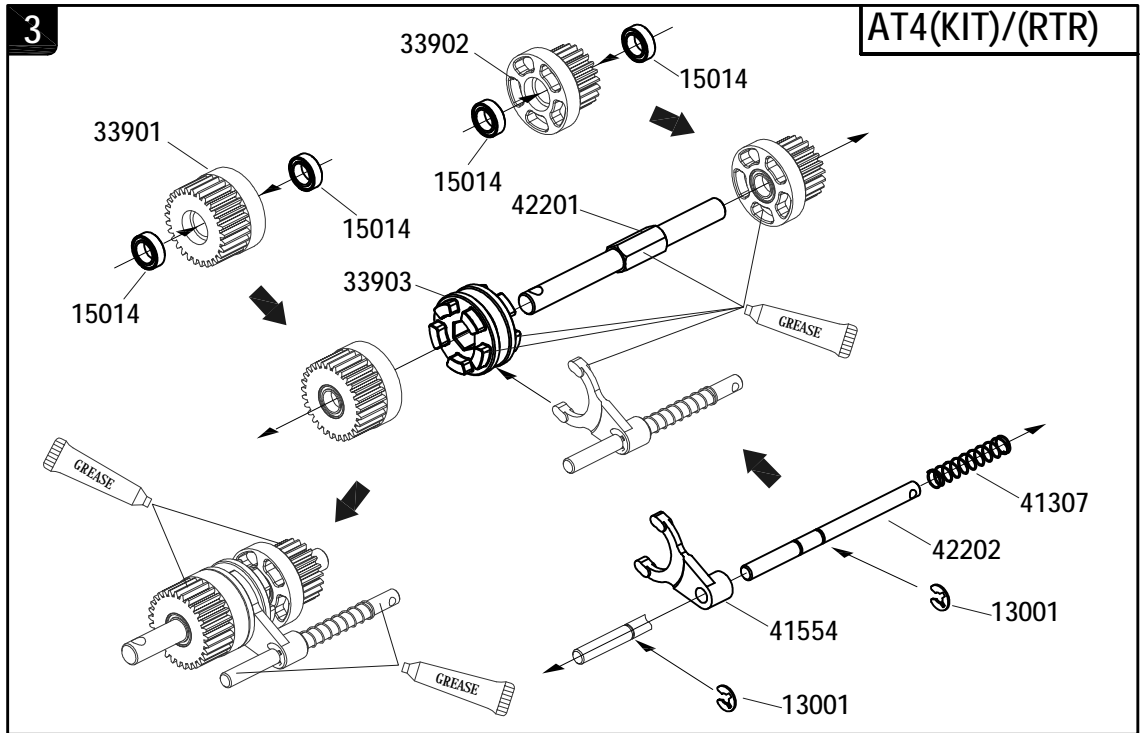

4

15012



∅5x∅10x4 X5

11207



M3x10 X3

42203



∅5.1x∅8x1.5 X3

72003



∅5x∅8x0.5 X1

72026



∅5x∅8x0.2 X1

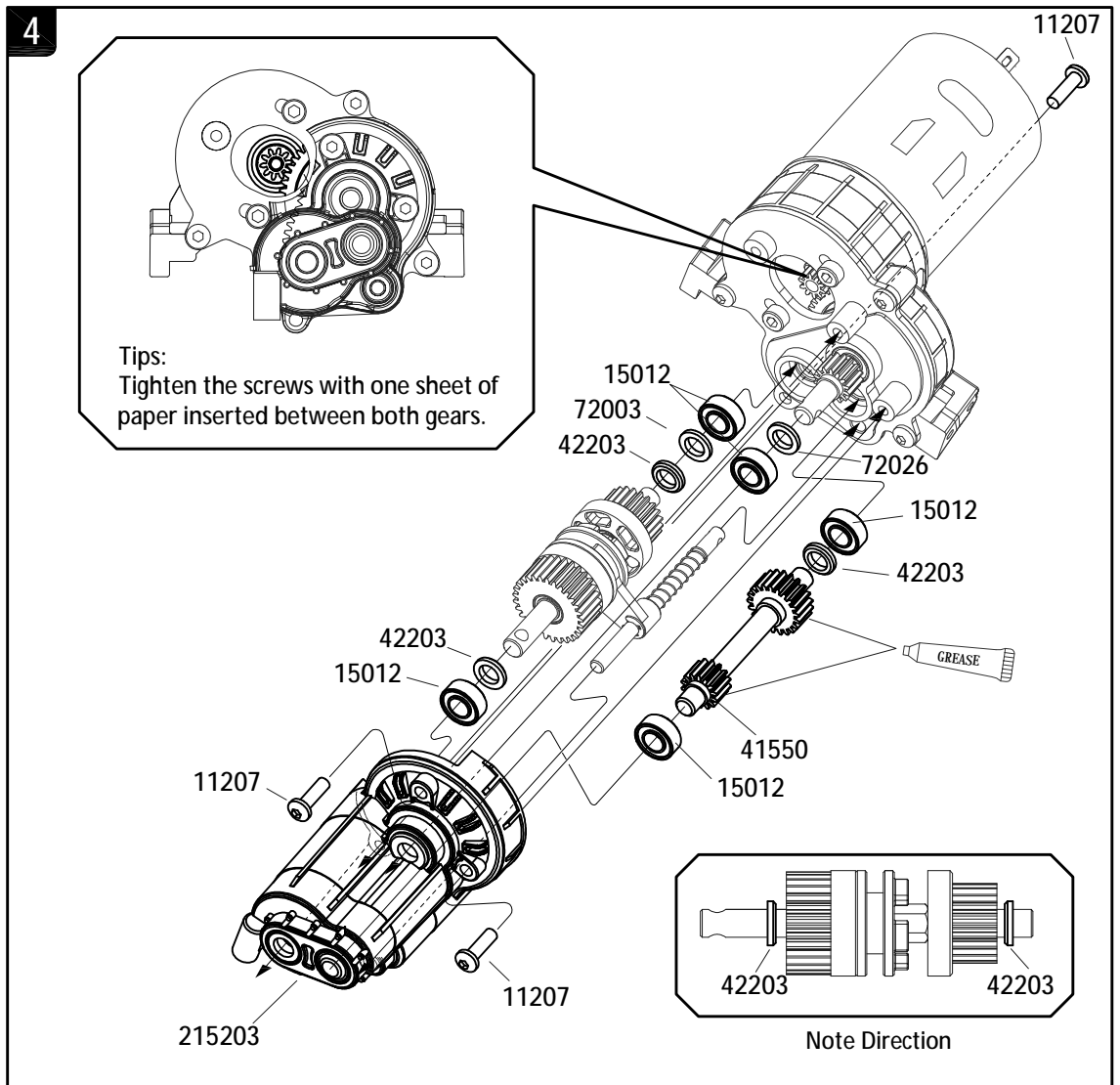



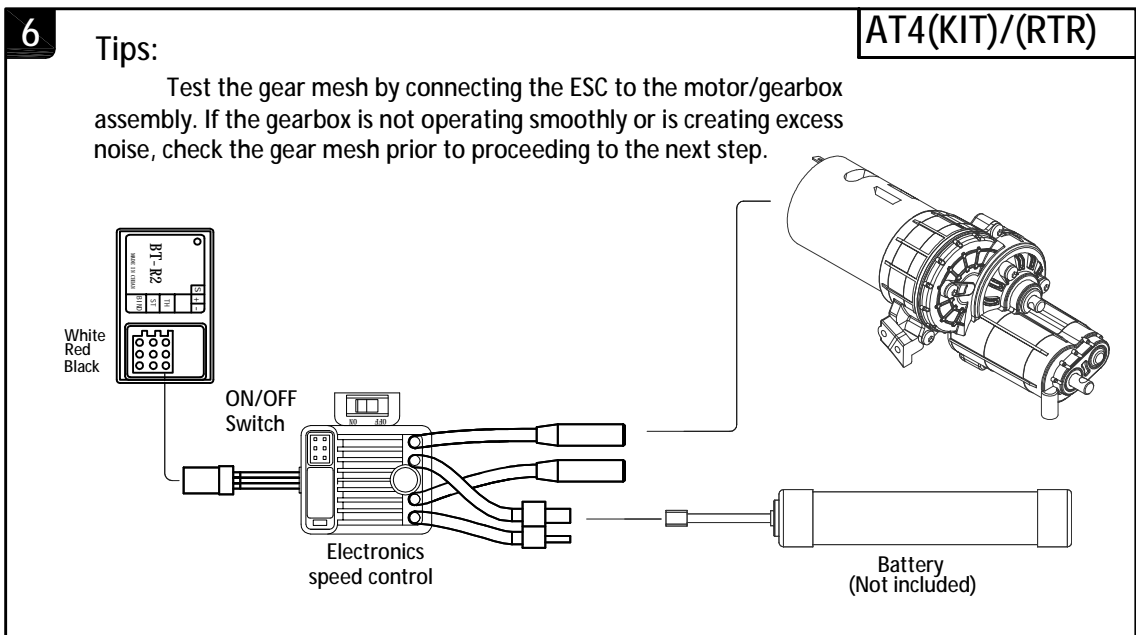
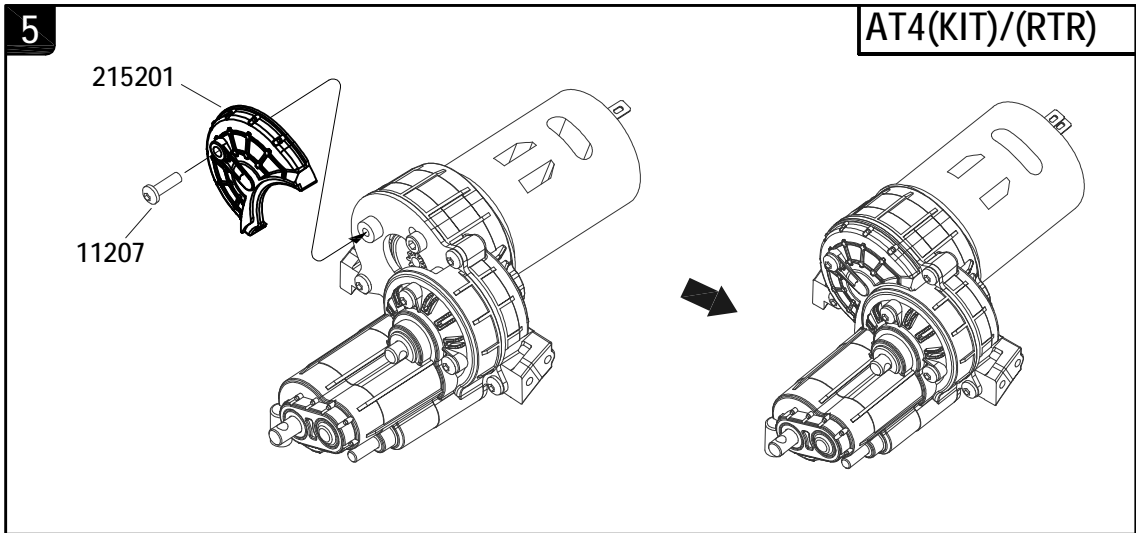

BAG(D)

- 11207  M3x10 X1



BAG(C)

- 11125  M2.5x10 X4
- 15012   $\phi 5 \times \phi 10 \times 4$ X6
- 72026   $\phi 5 \times \phi 8 \times 0.2$ X6

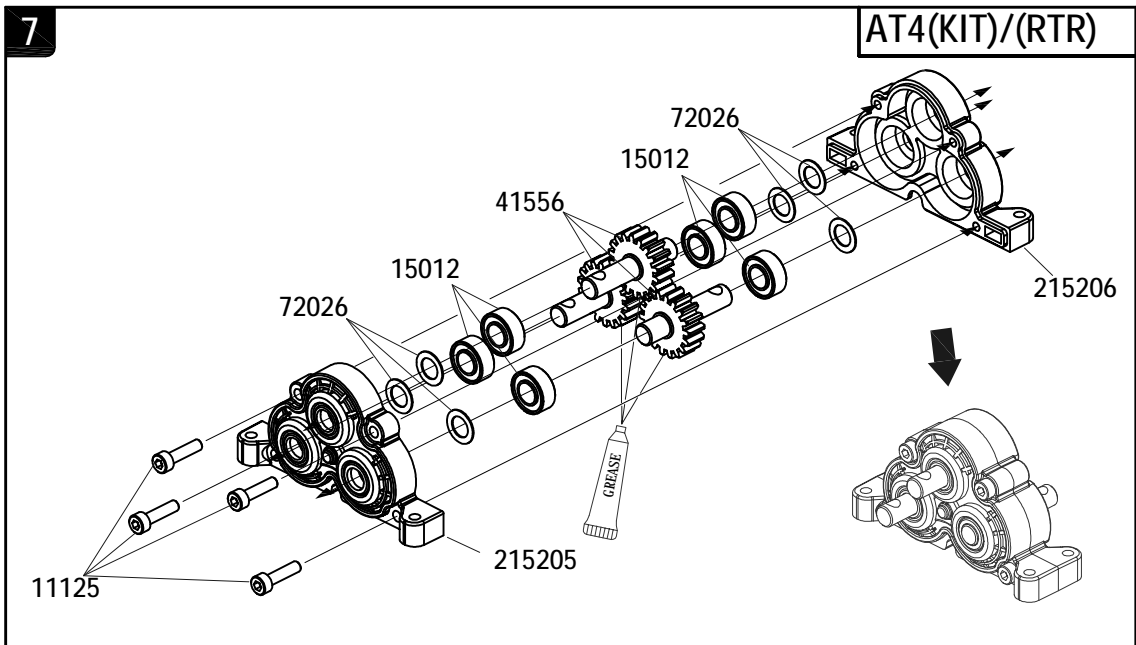

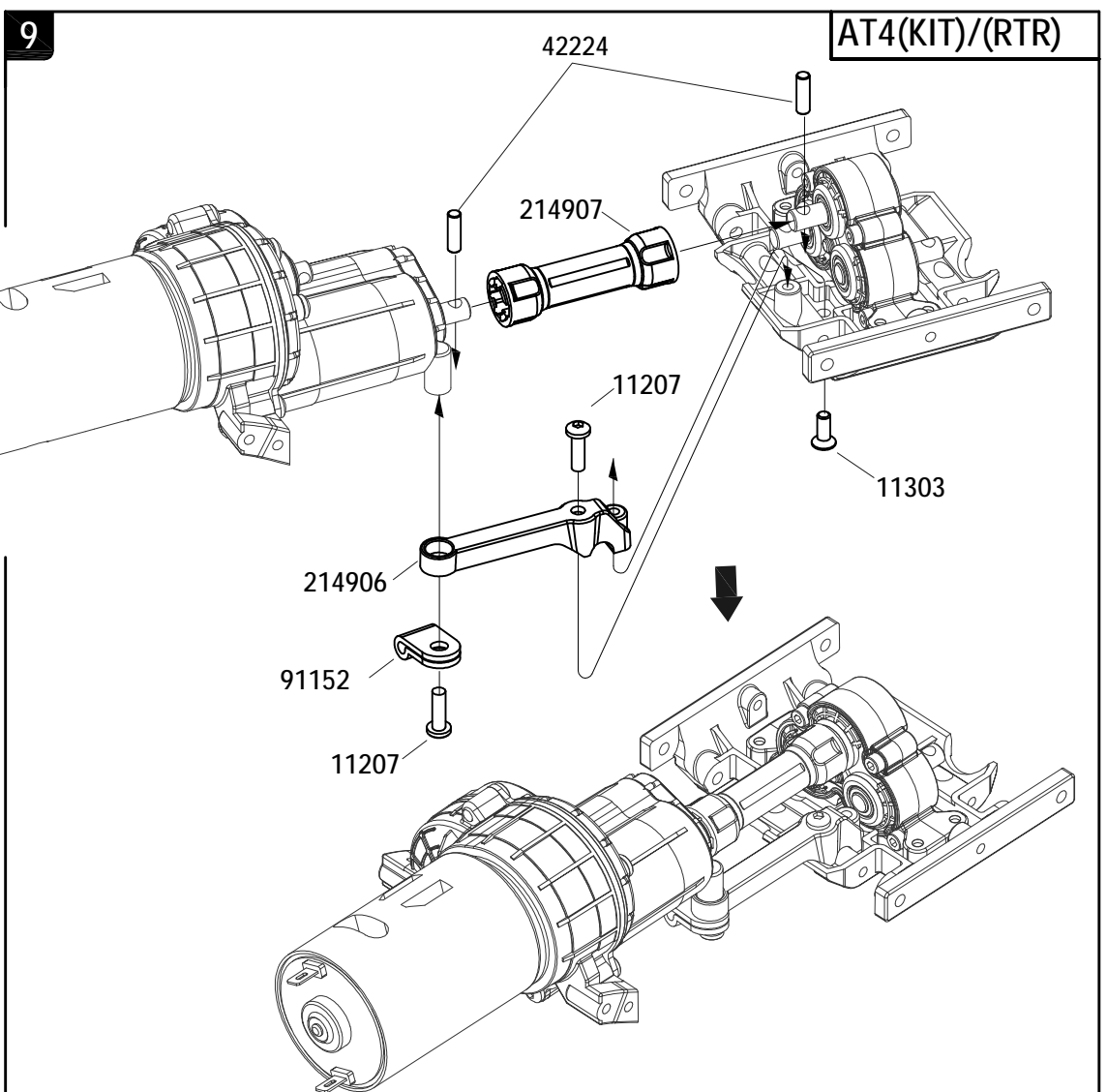
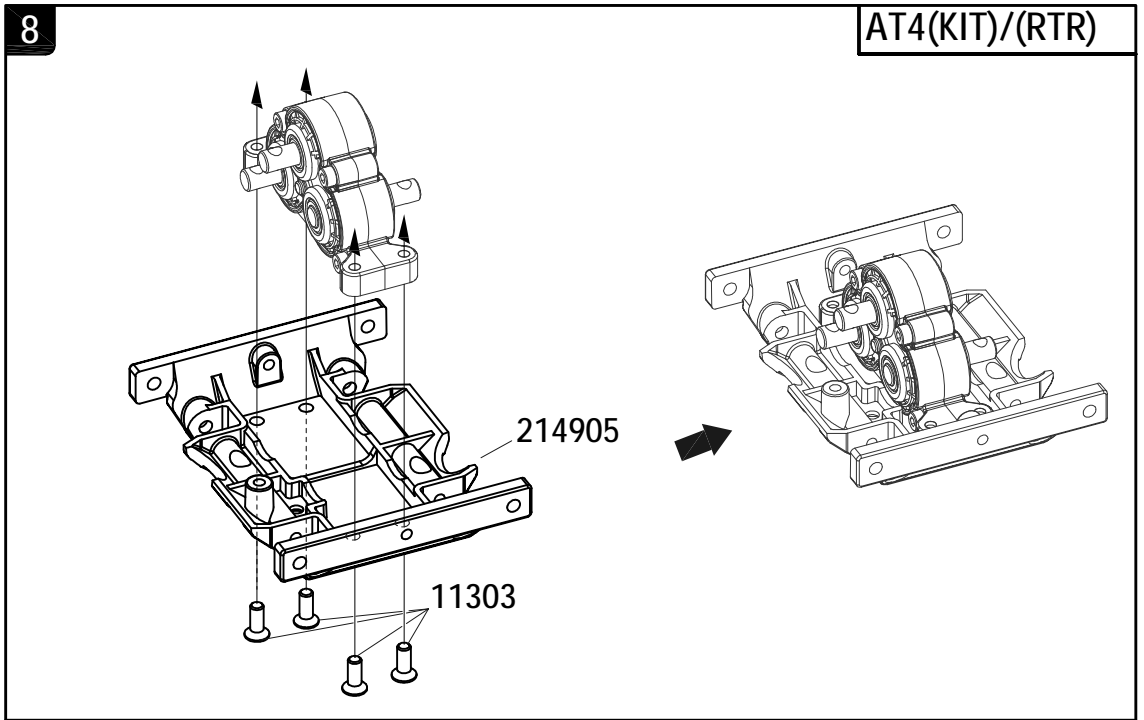

BAG(V)

11303 
M3x8 X4



11303 
M3x8 X1

11207 
M3x10 X2

42224 
Ø3x10.8 X2

BAG(V)

10

AT4(KIT)/(RTR)

11107 
M3x10 X9

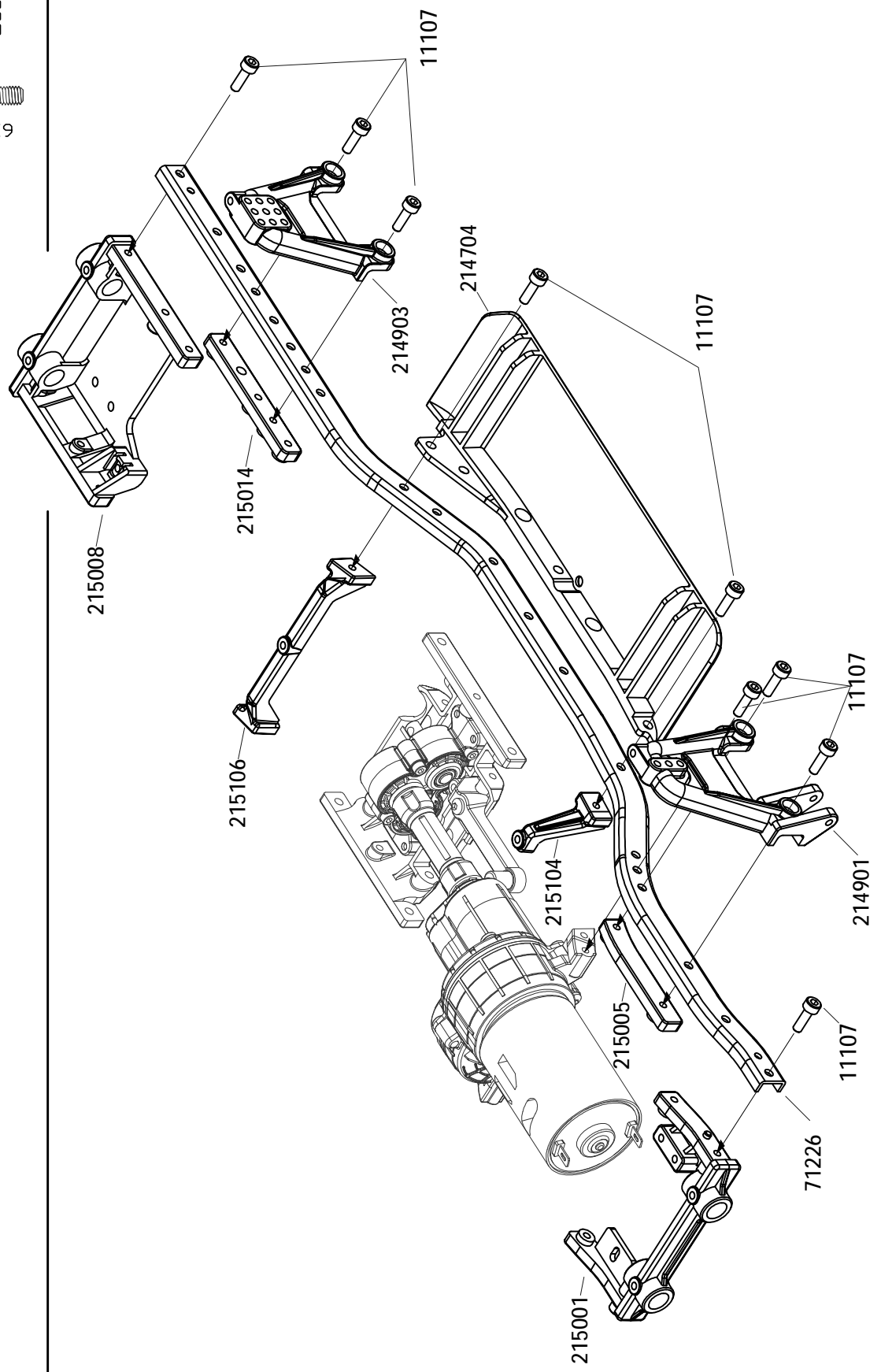

BAG(V)

11

AT4(KIT)/(RTR)

11107 
M3x10 X9

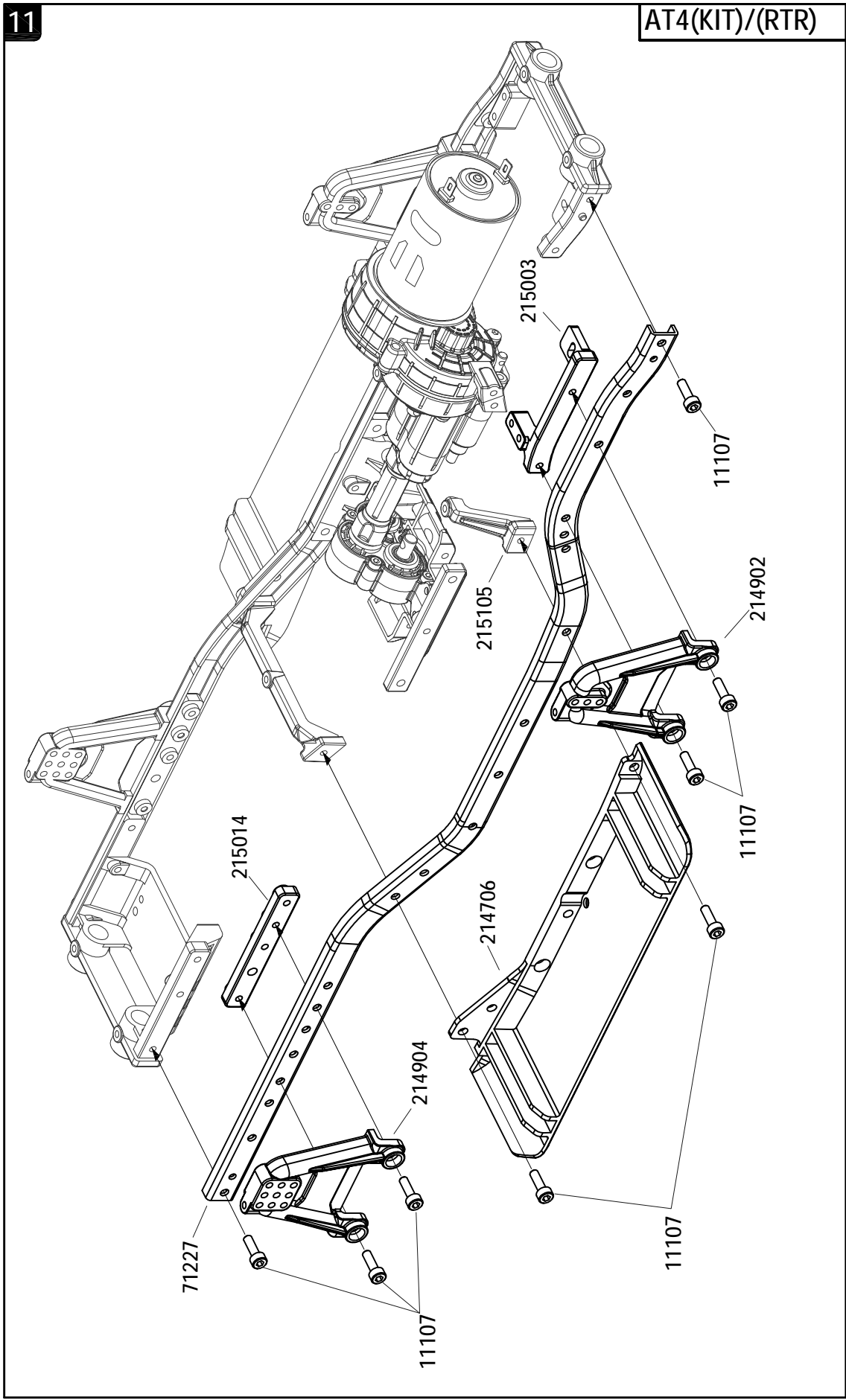

BAG(V)

11206 M3x8 X10

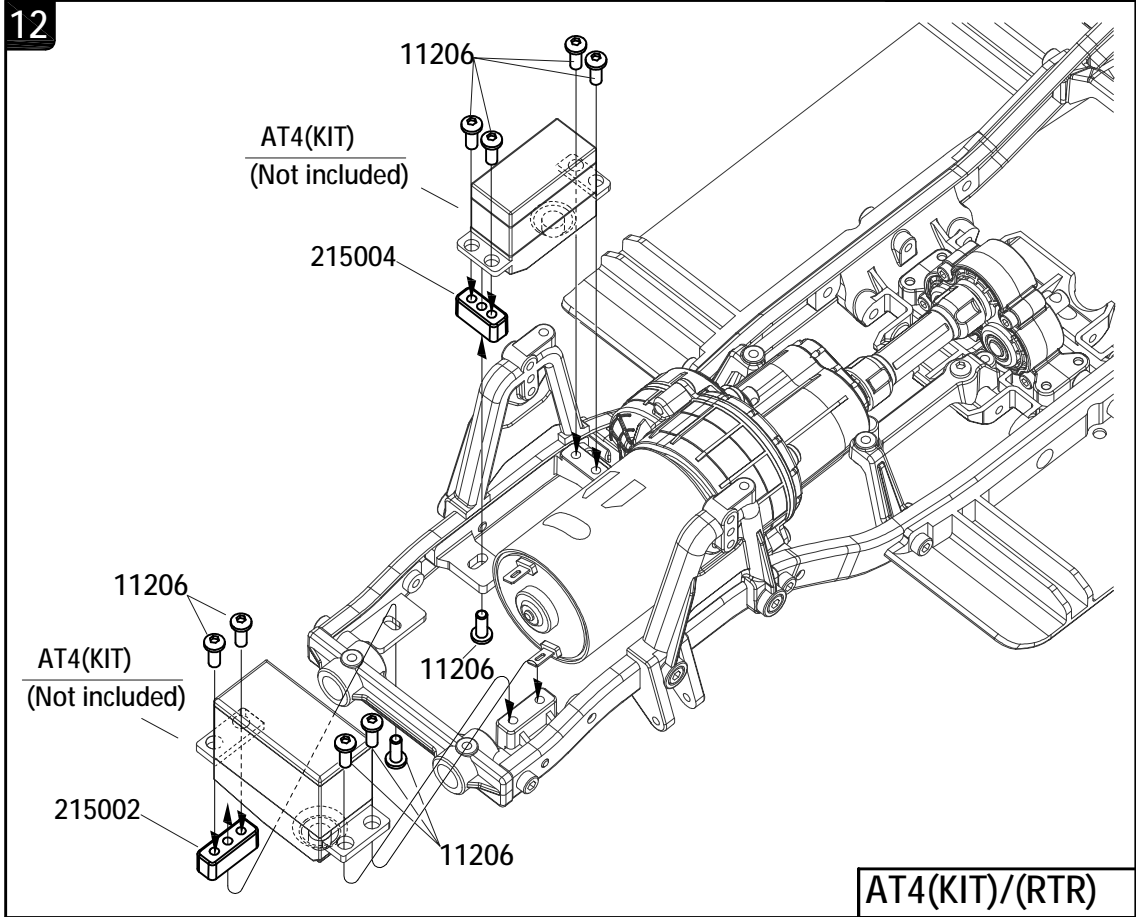

11206 M3x8 X6

11116 M2.5x12 X1

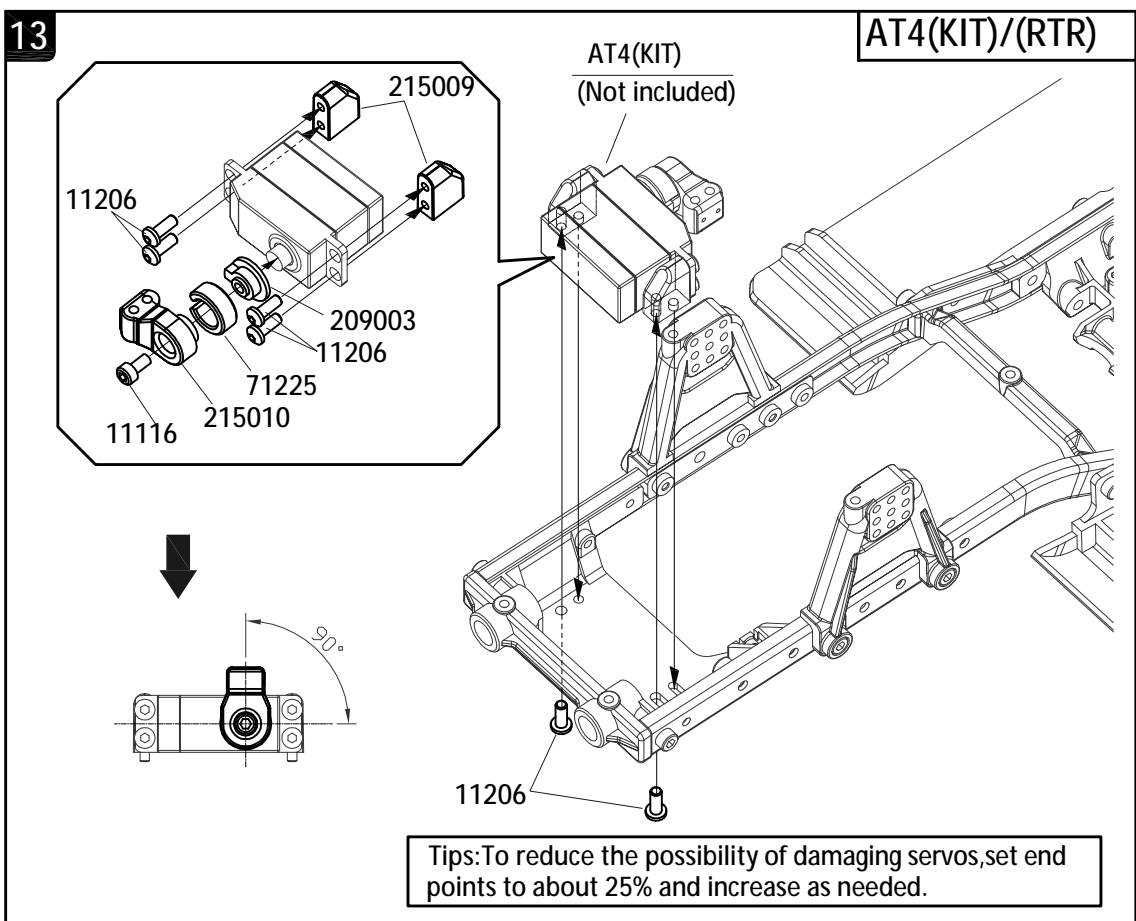



BAG(V)

11207 
M3x10 X4

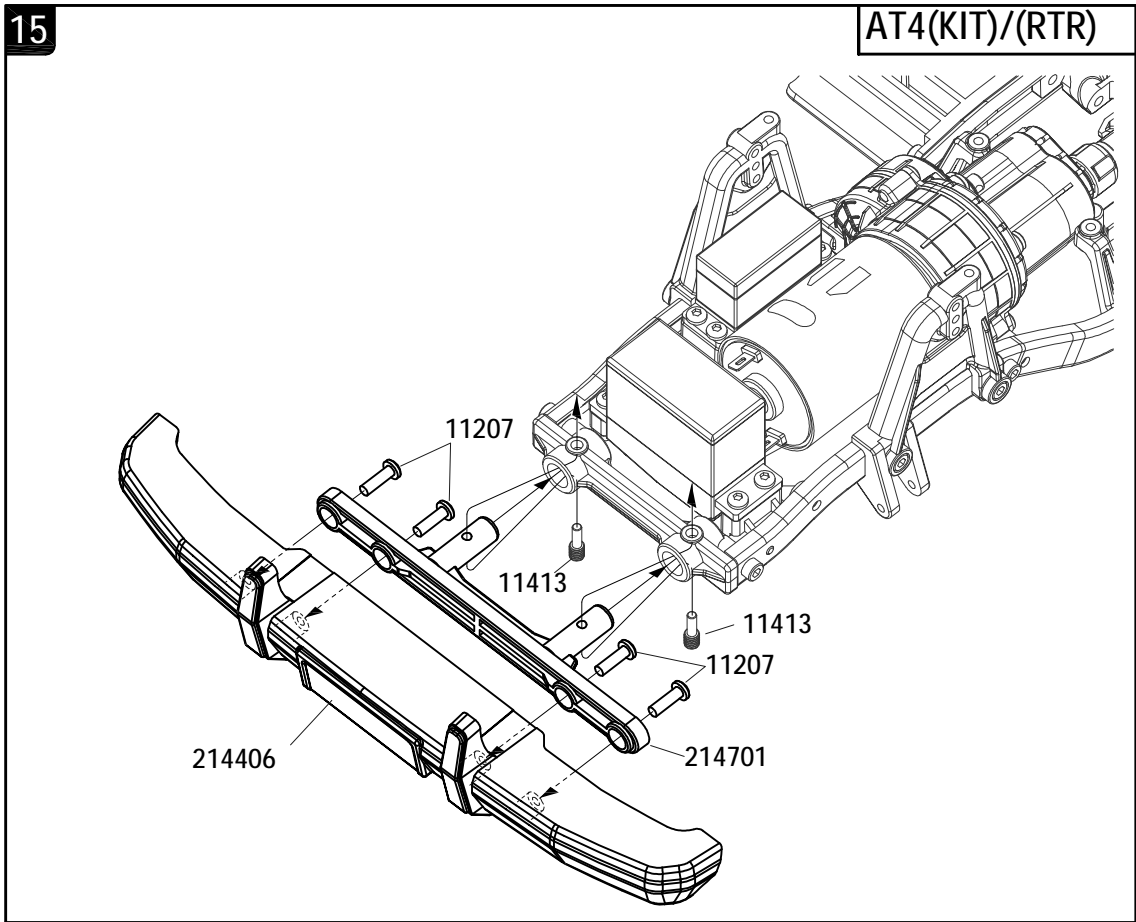
11413 
M4x12 X2



11207 
M3x10 X4

11413 
M4x12 X2

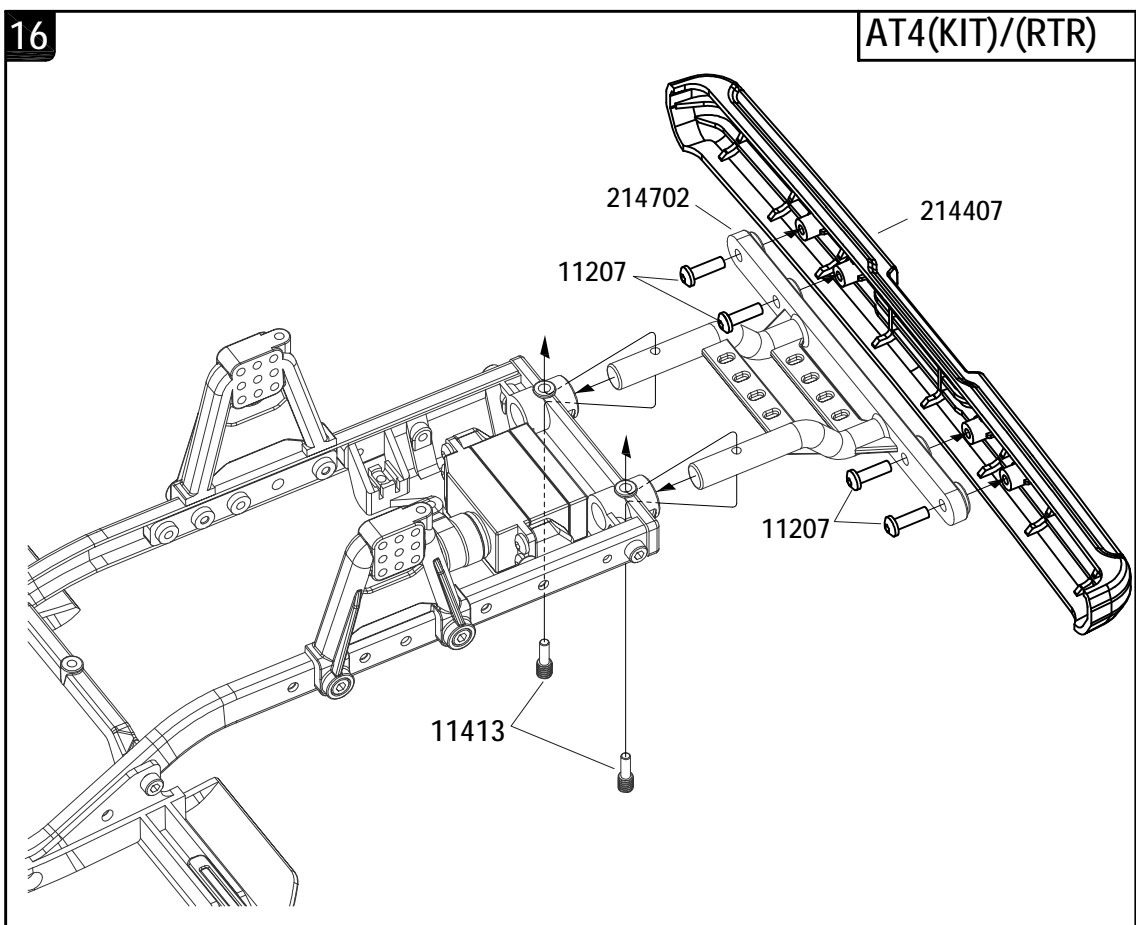

BAG(V)

17

AT4(KIT)/(RTR)

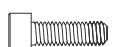
11107 
M3x10 X10

11207 
M3x10 X1

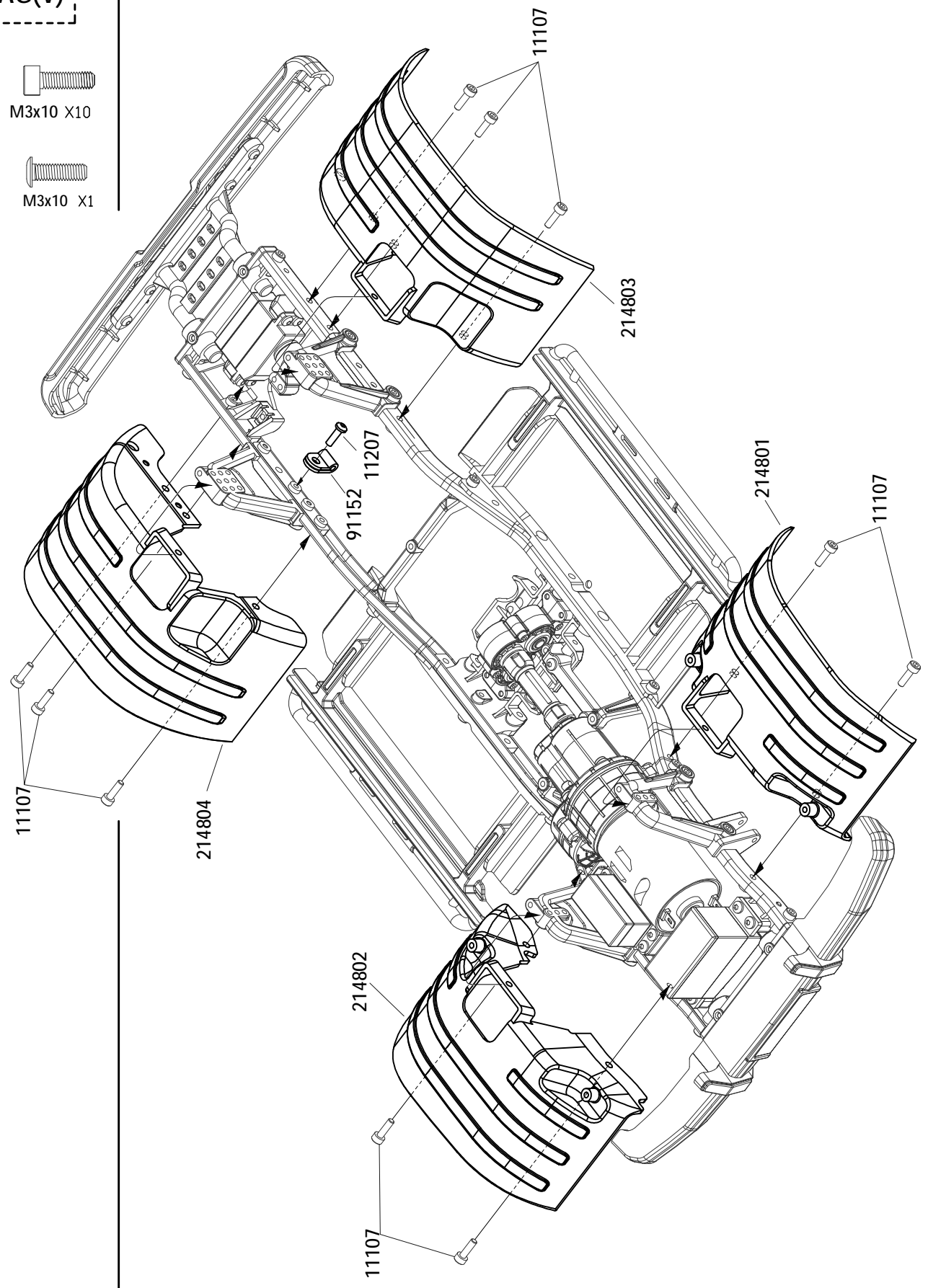

BAG(B)

13004  |
 φ2.0xφ5.5x0.4 X8

φ6.5xφ2.5xφ2



17007 X12

φ7xφ5xφ1



17008 X4



41336 X4



White mark

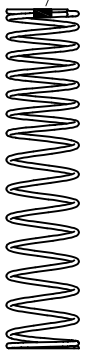

41802 X2(1.1)

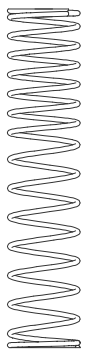

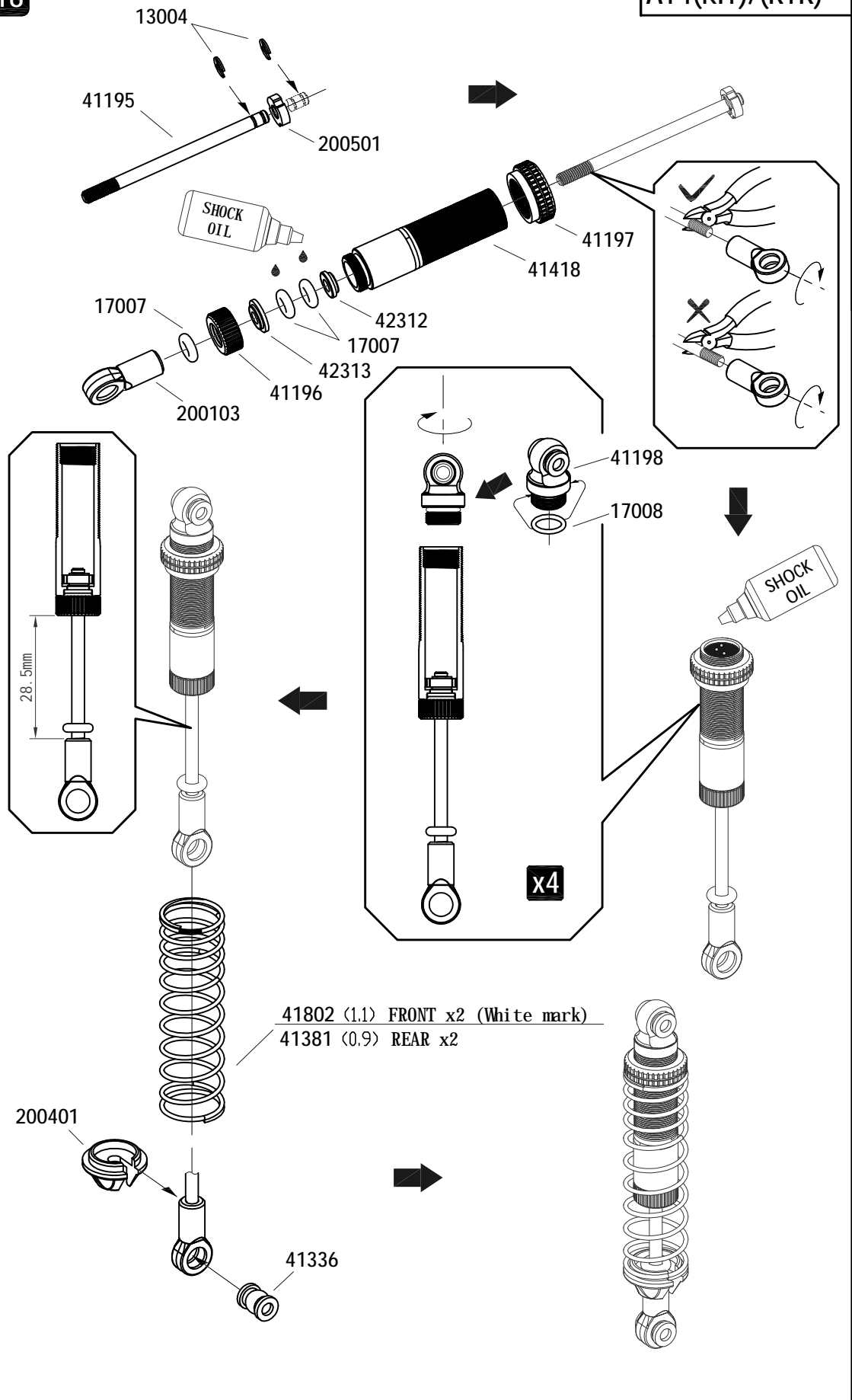

41381 X2(0.9)





41802 (1.1) FRONT x2 (White mark)
 41381 (0.9) REAR x2

BAG(E)

11316  M2.5x10 X2

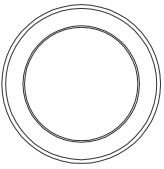
11227  M2.5x8 X8

15015  $\phi 15 \times \phi 21 \times 4$ X2

15013  $\phi 10 \times \phi 15 \times 4$ X2

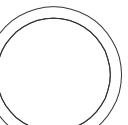
75020  $\phi 15 \times \phi 18 \times 0.2$ X2

15012  $\phi 5 \times \phi 10 \times 4$ X2

13002  $\phi 3.8 \times \phi 9.2 \times 0.6$ X1

72007  $\phi 5 \times \phi 8 \times 0.3$ X1

11125  M2.5x10 X4

11205  M3x6 X4

12203  M3 X2

11211  M3x18 X2

15012  $\phi 5 \times \phi 10 \times 4$ X2

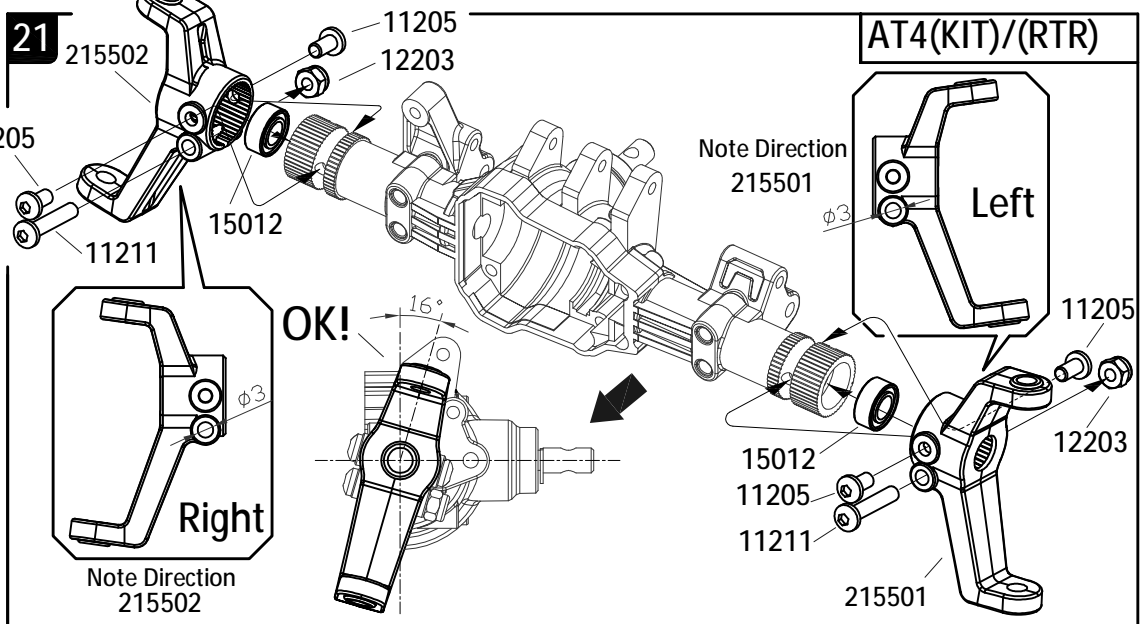
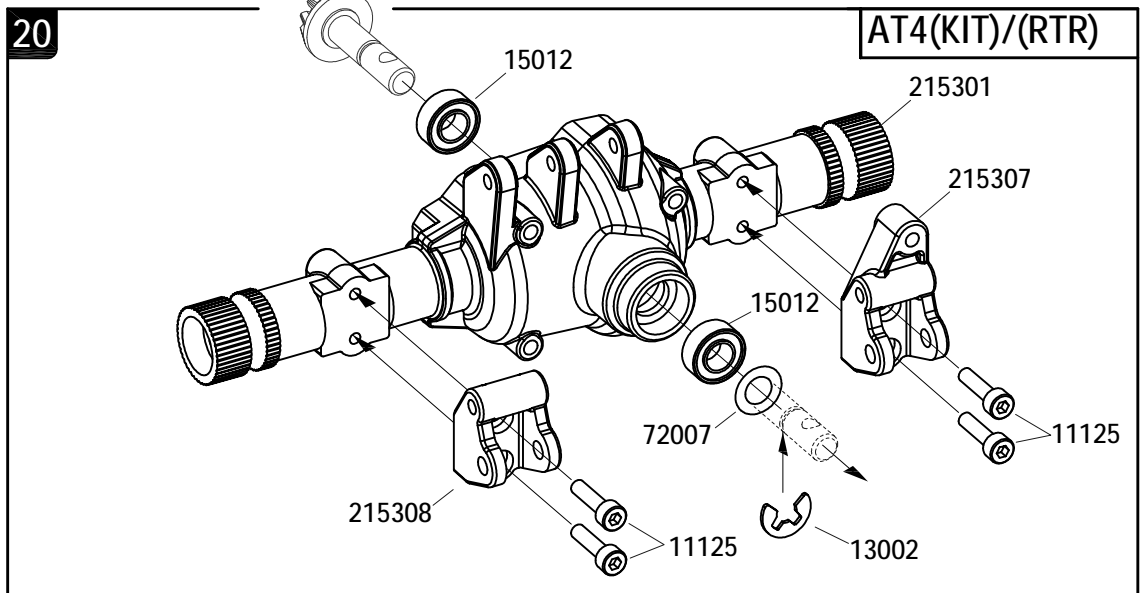
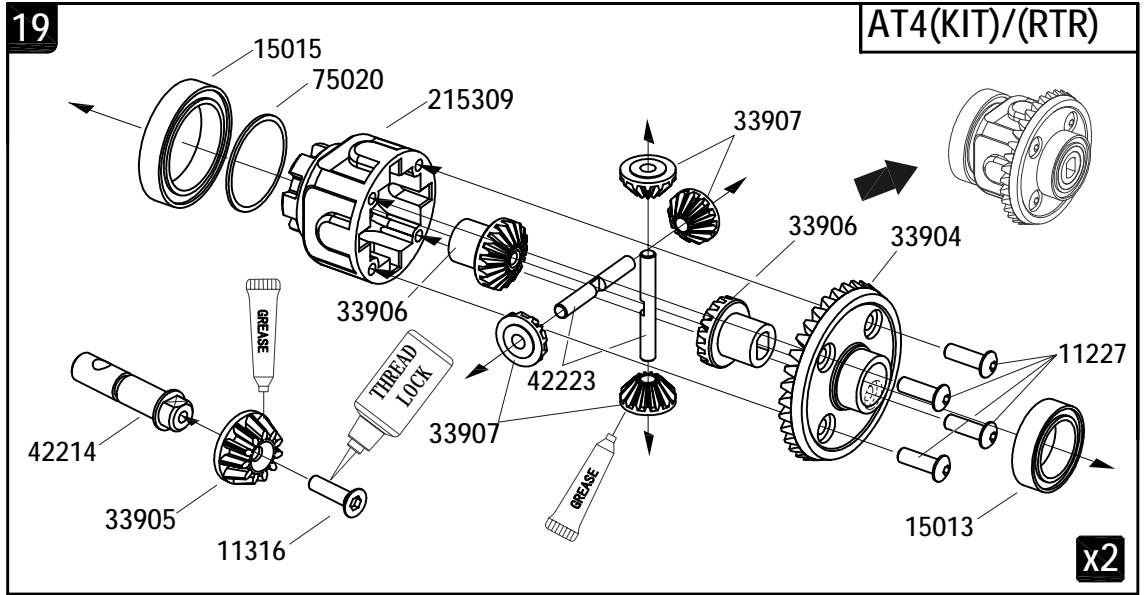

BAG(E)

24

AT4(KIT)/(RTR)

42208
M3x10 X4

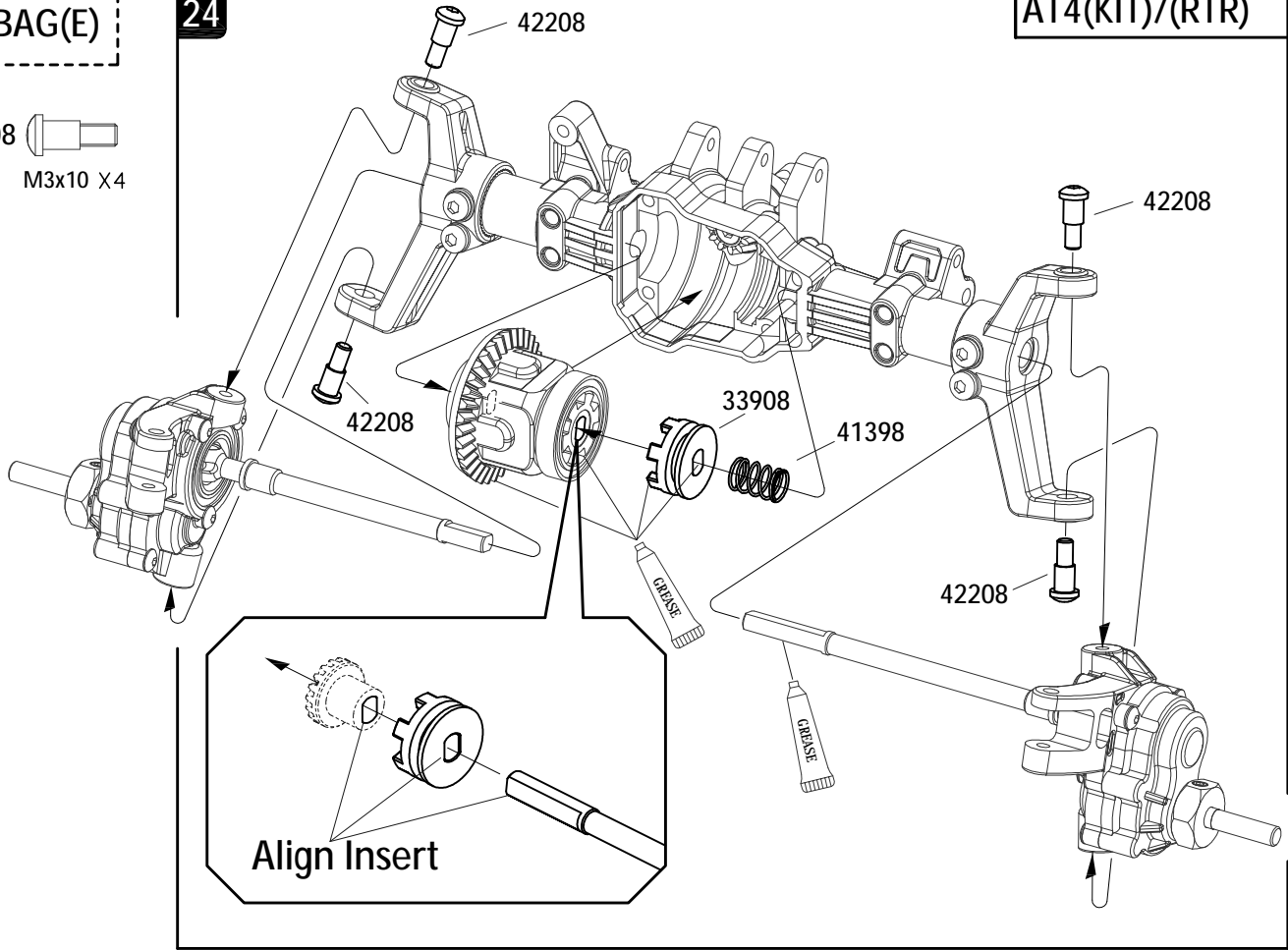

25

AT4(KIT)/(RTR)

11412
M3x3 X1

42209 X1

11133
M2x12 X2

11136
M2.5x18 X4

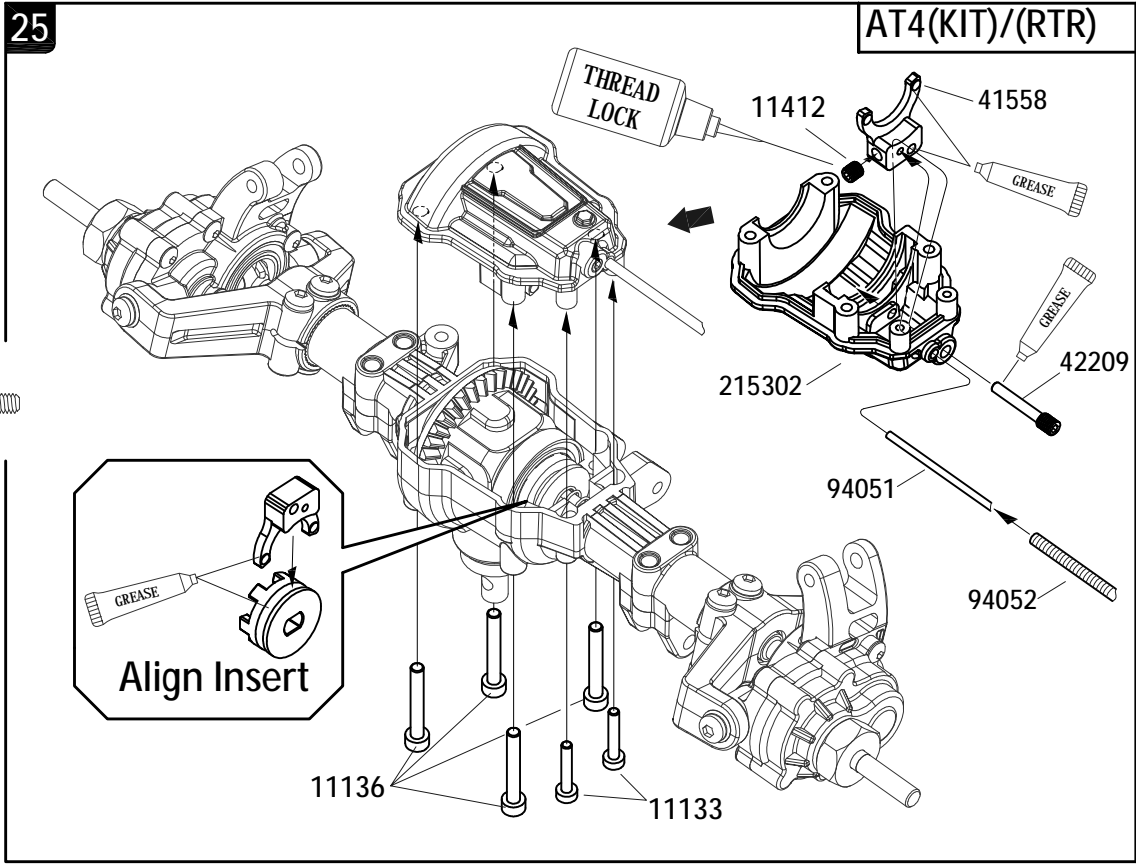

BAG(E)

26





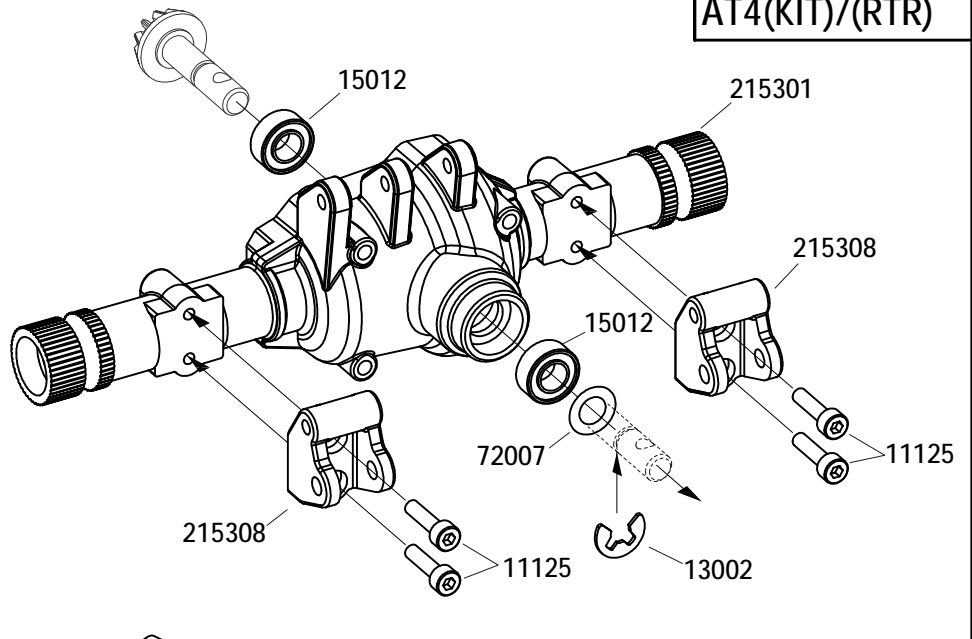

AT4(KIT)/(RTR)

- 15012  
ø5xø10x4 X2
- 13002  
ø3.8xø9.2x0.6 X1
- 72007  
ø5xø8x0.3 X1
- 11125 
M2.5x10 X4



27

AT4(KIT)/(RTR)

- 11217 
M2.5x10 X12
- 15017  
ø6xø12x4 X2
- 11412 
M3x3 X2
- 15012  
ø5xø10x4 X6

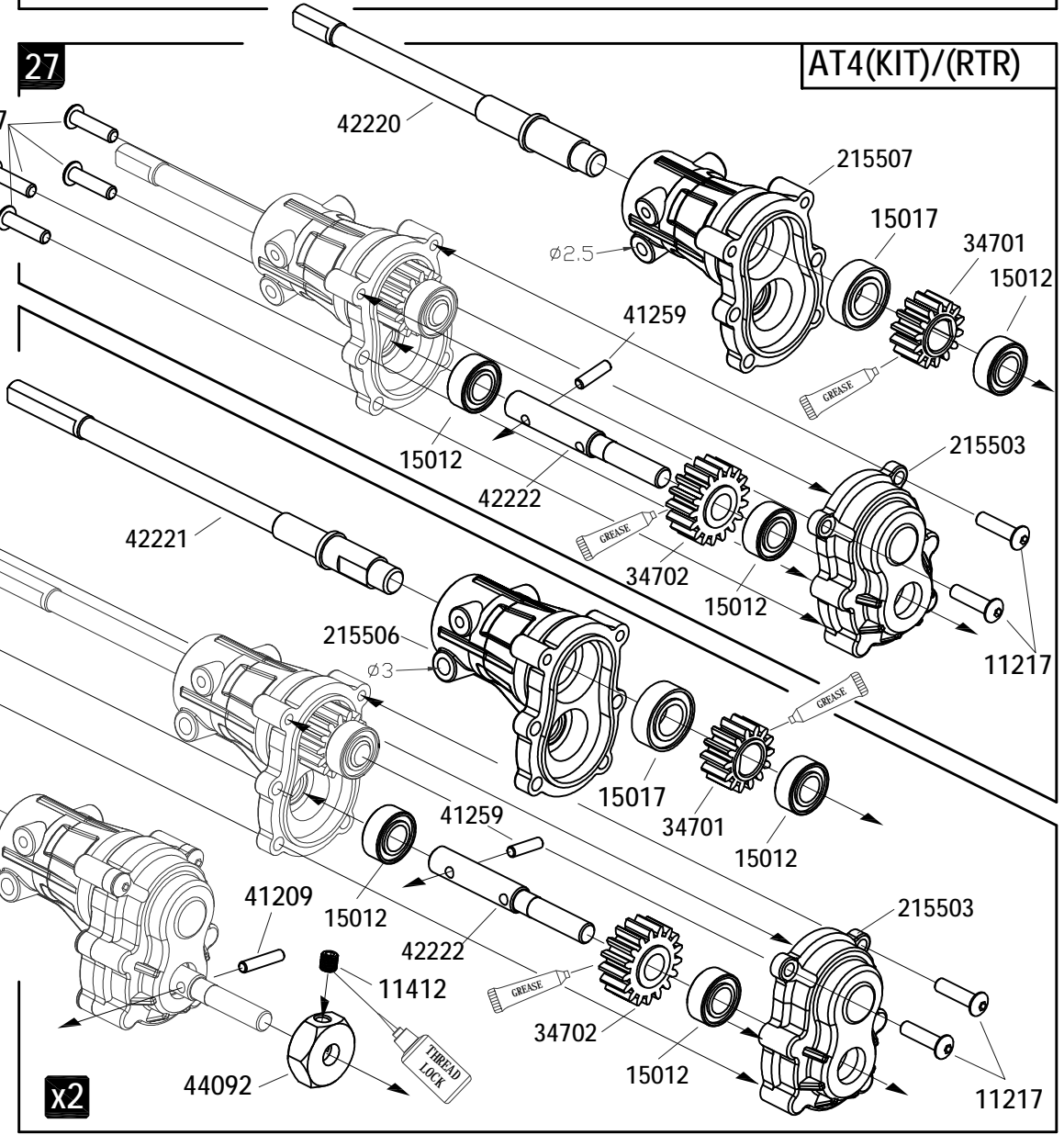

BAG(E)

28

AT4(KIT)/(RTR)

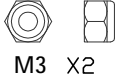
12203  M3 X2

11211  M3x18 X2

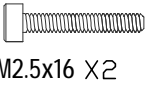
11119  M2.5x16 X2

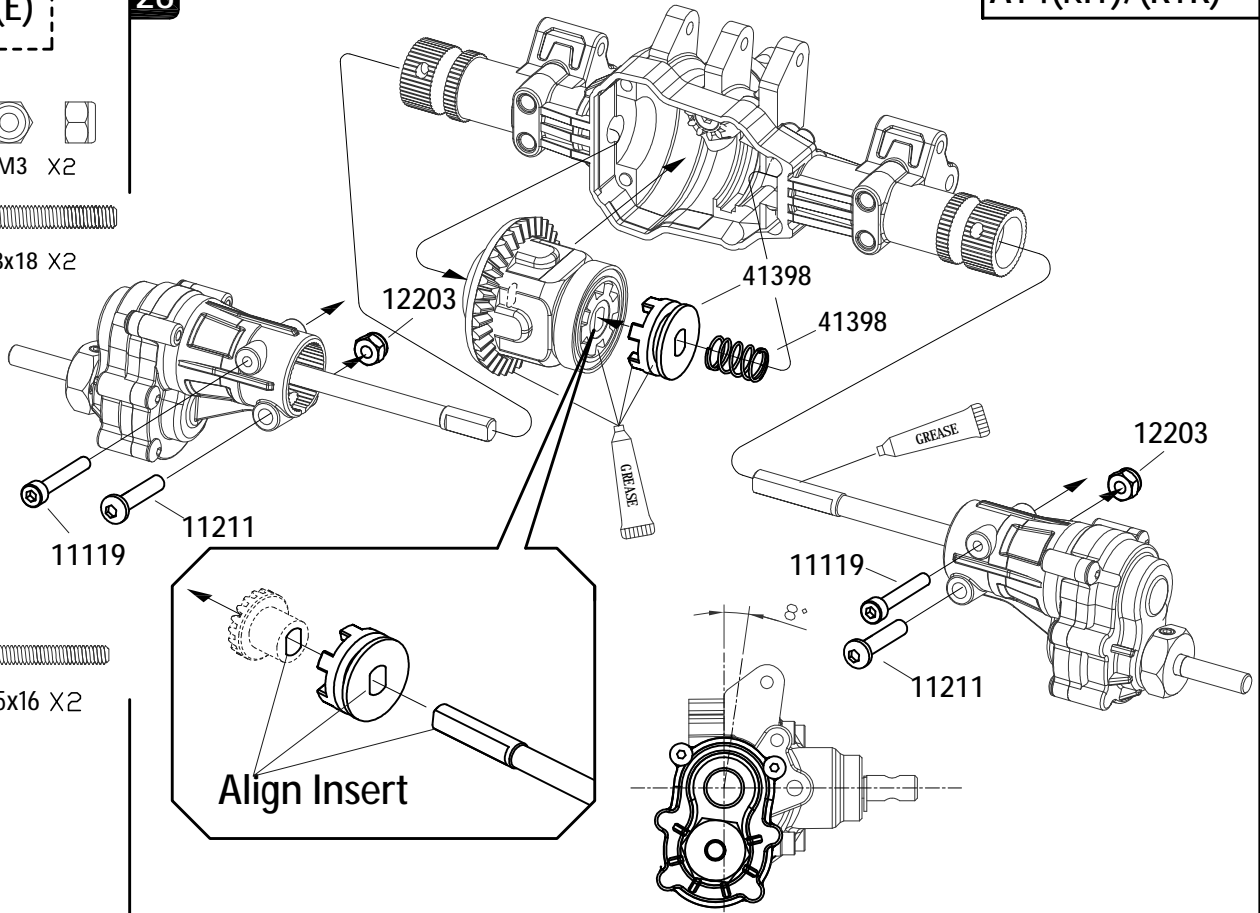

29

AT4(KIT)/(RTR)

11412  M3x3 X1

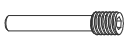

42209 X1

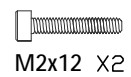
11133  M2x12 X2

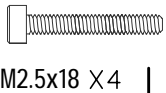
11136  M2.5x18 X4

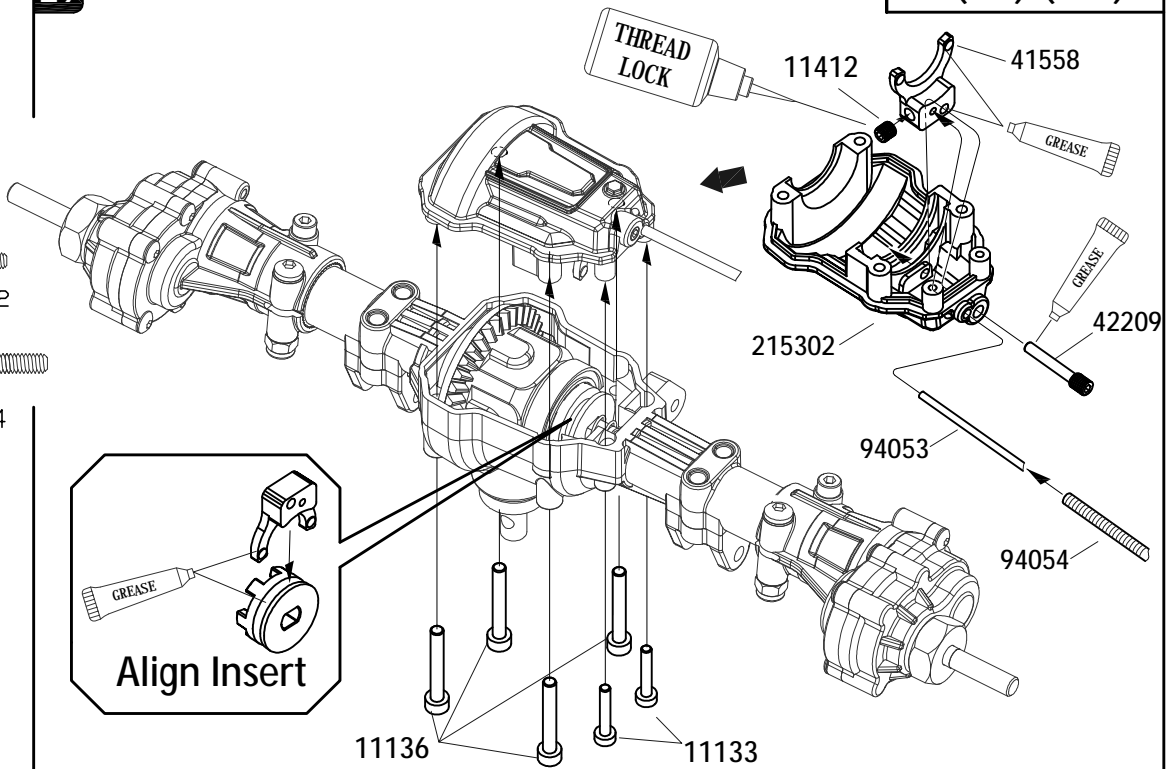

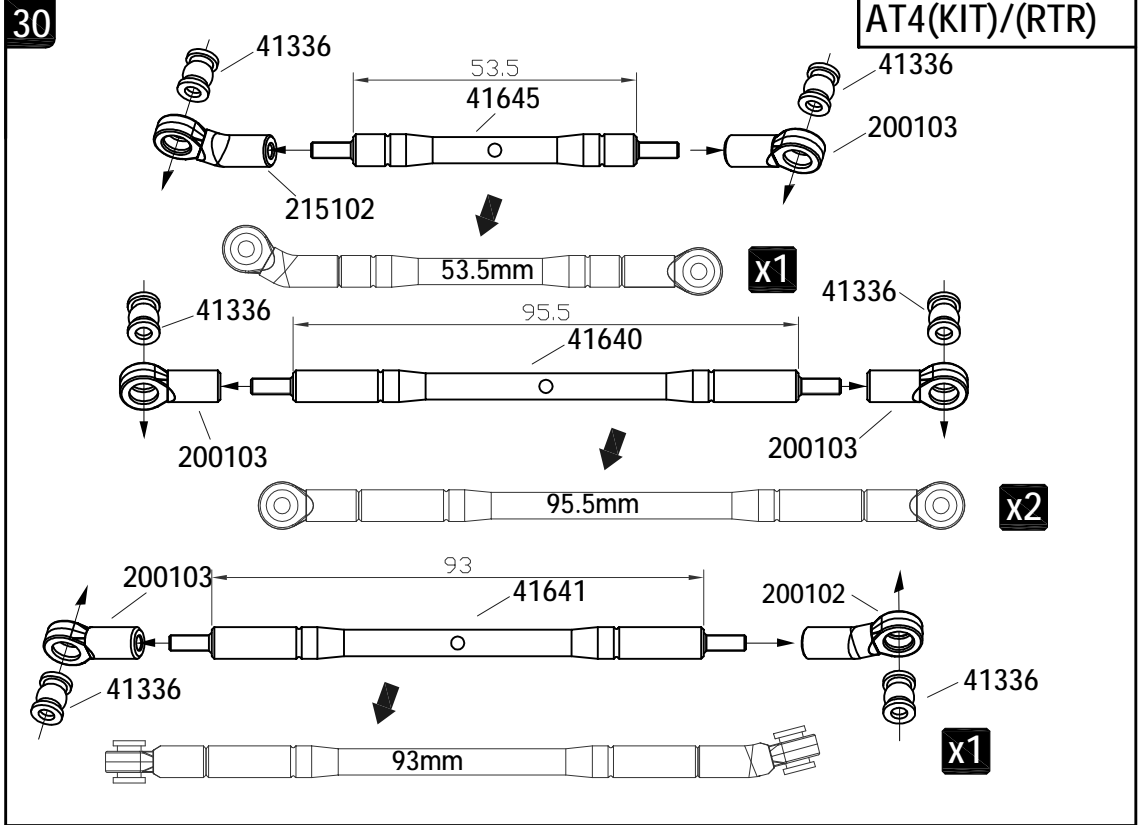

BAG(G)
BAG(H)

41336 X8



BAG(V)

- 11210  M3x16 X1
- 11211  M3x18 X2
- 11215  M3x28 X1

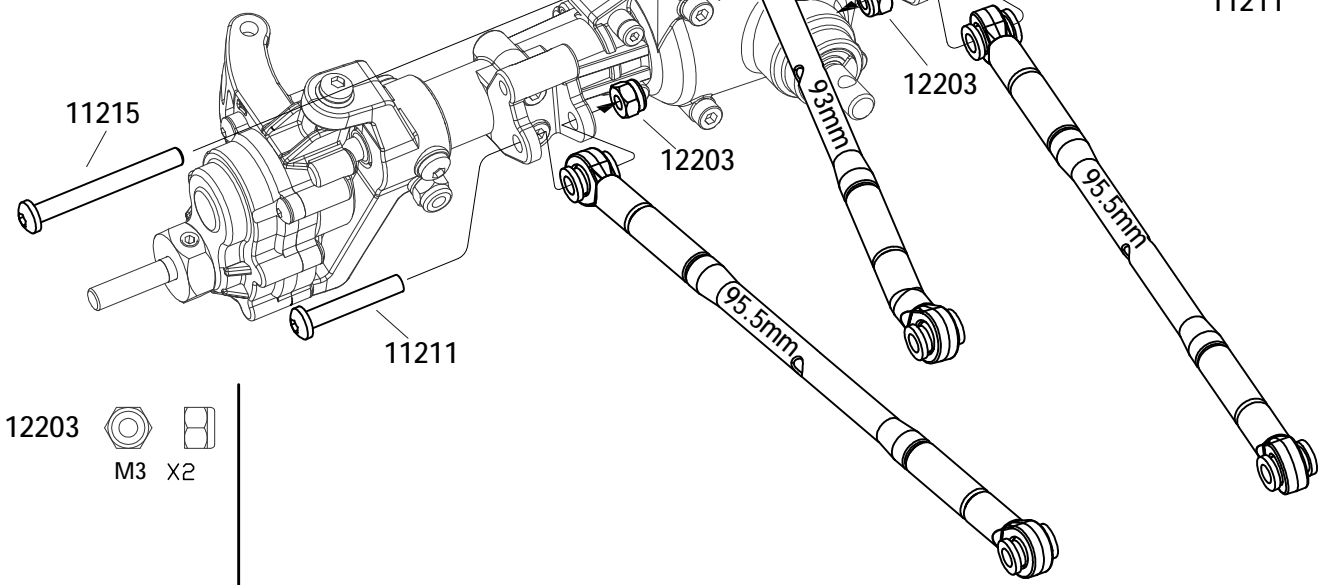

BAG(G)

BAG(H)



41336 X4

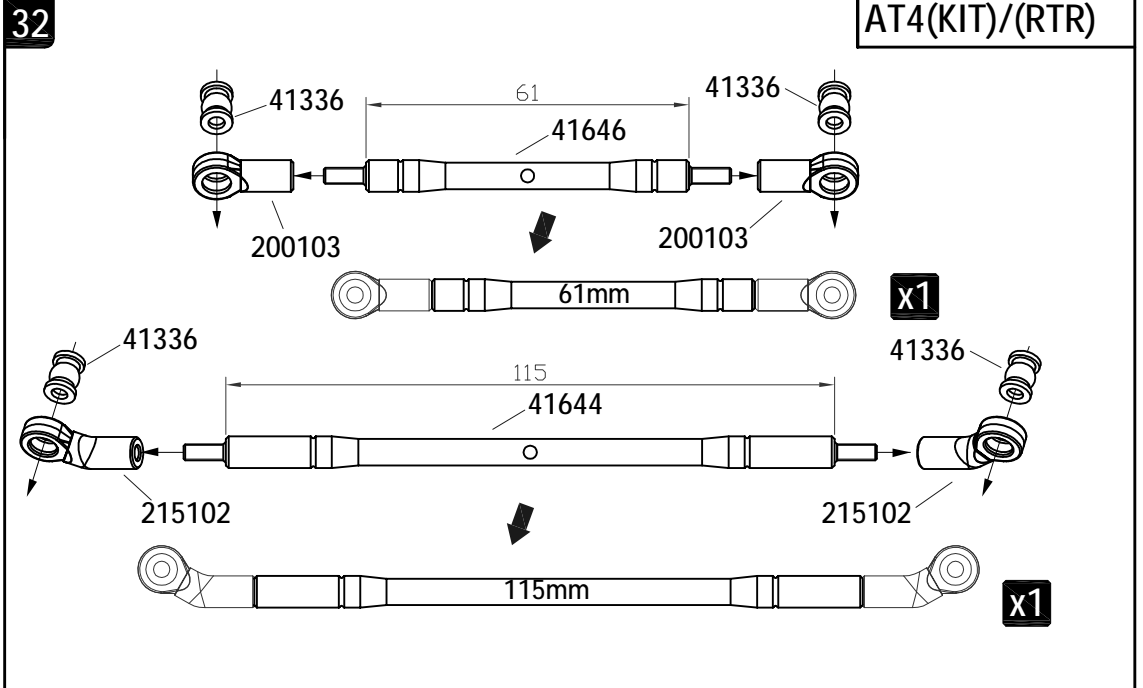

BAG(V)

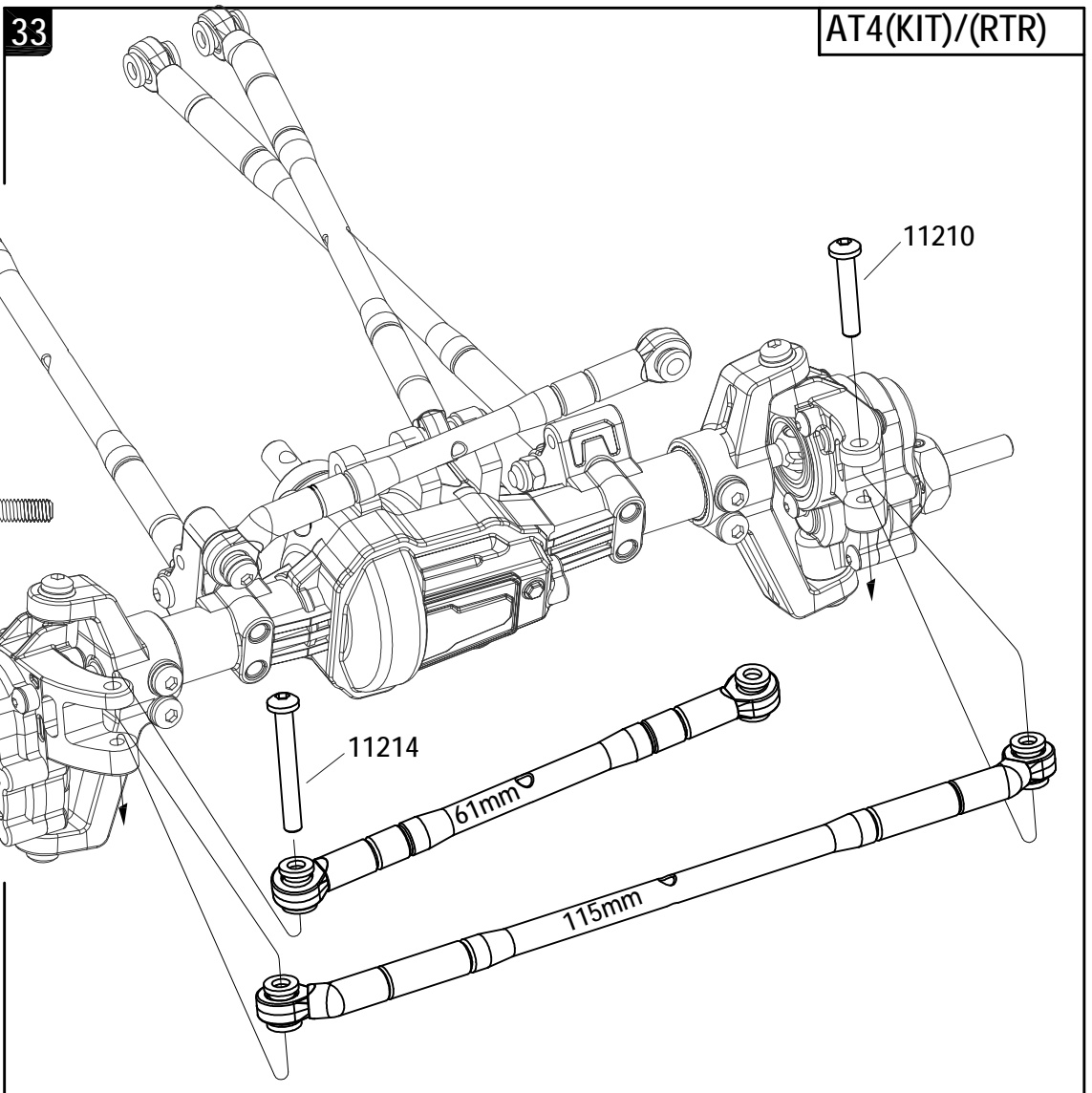

BAG(G)

BAG(H)



41336 X8

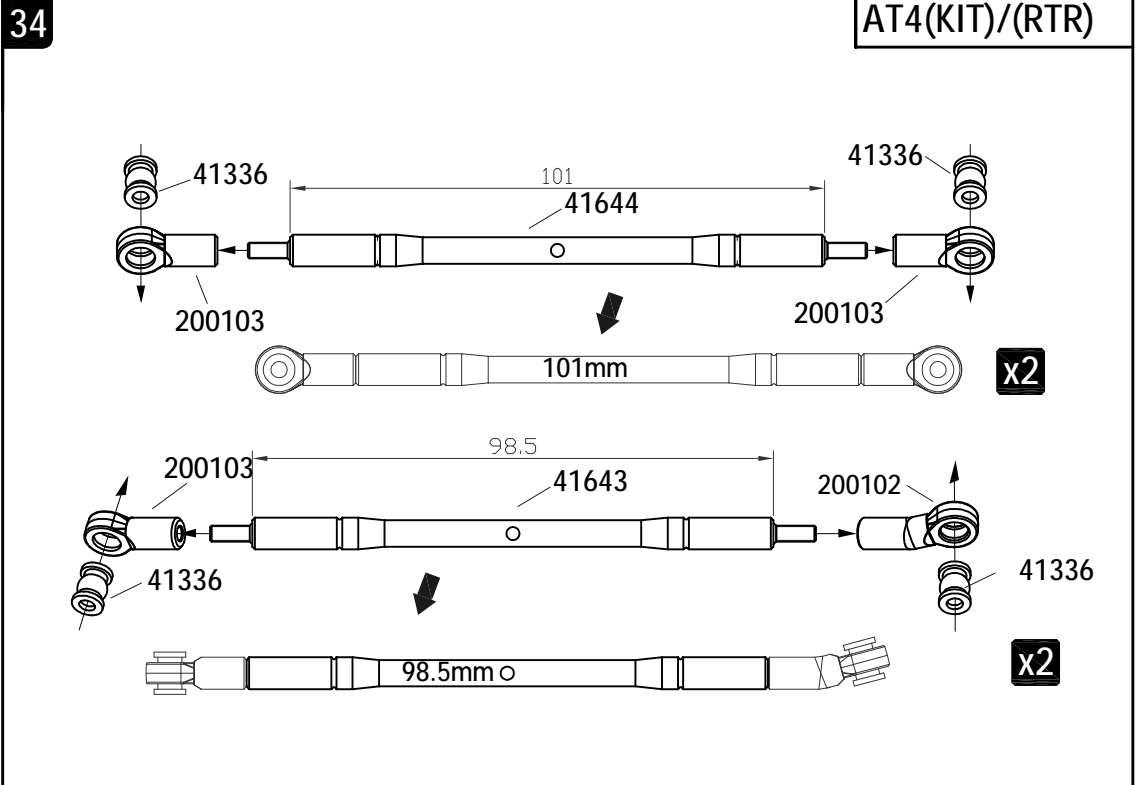

BAG(V)

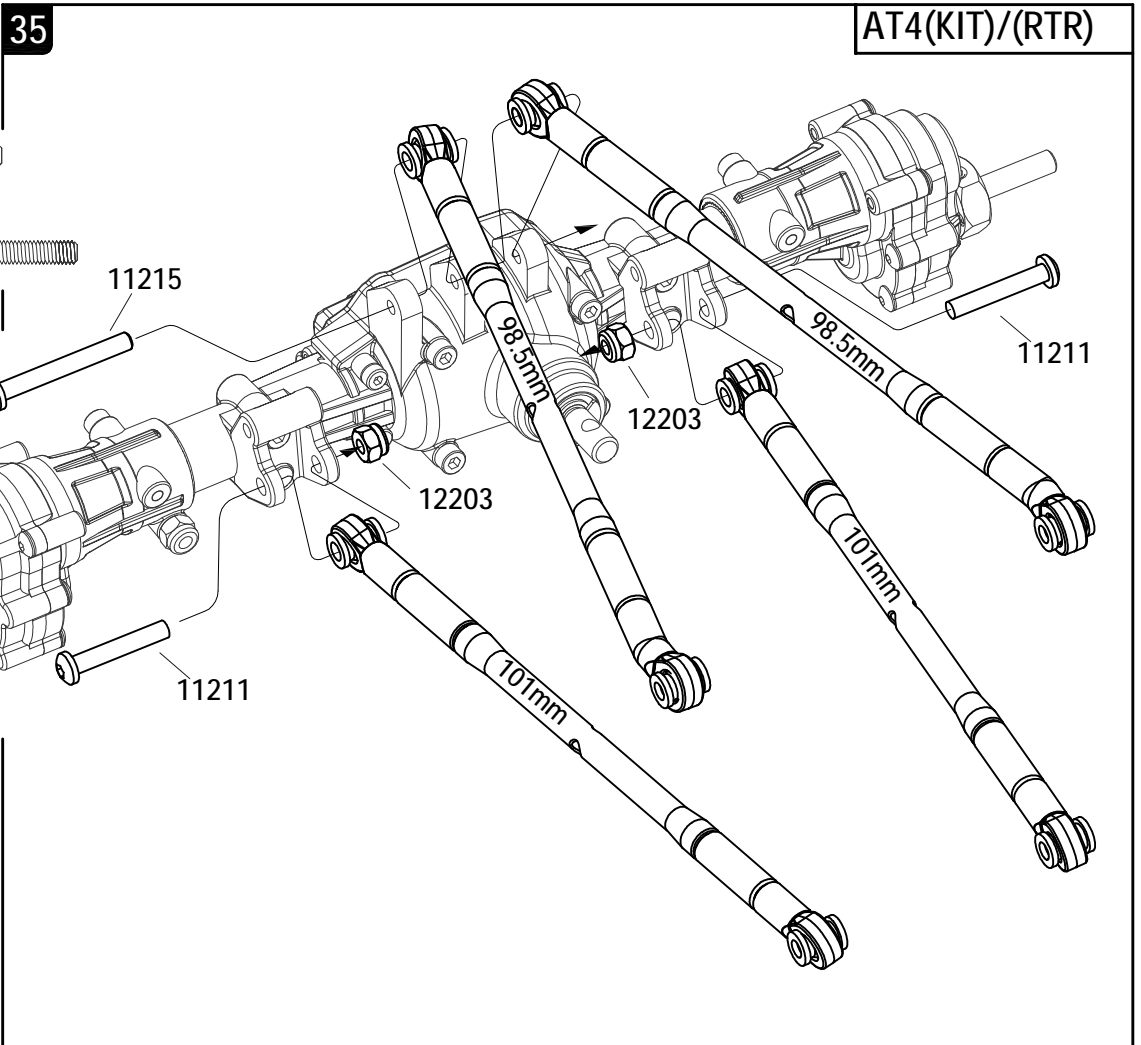

36

AT4(KIT)/(RTR)

BAG(I)

11205  M3x6 X2

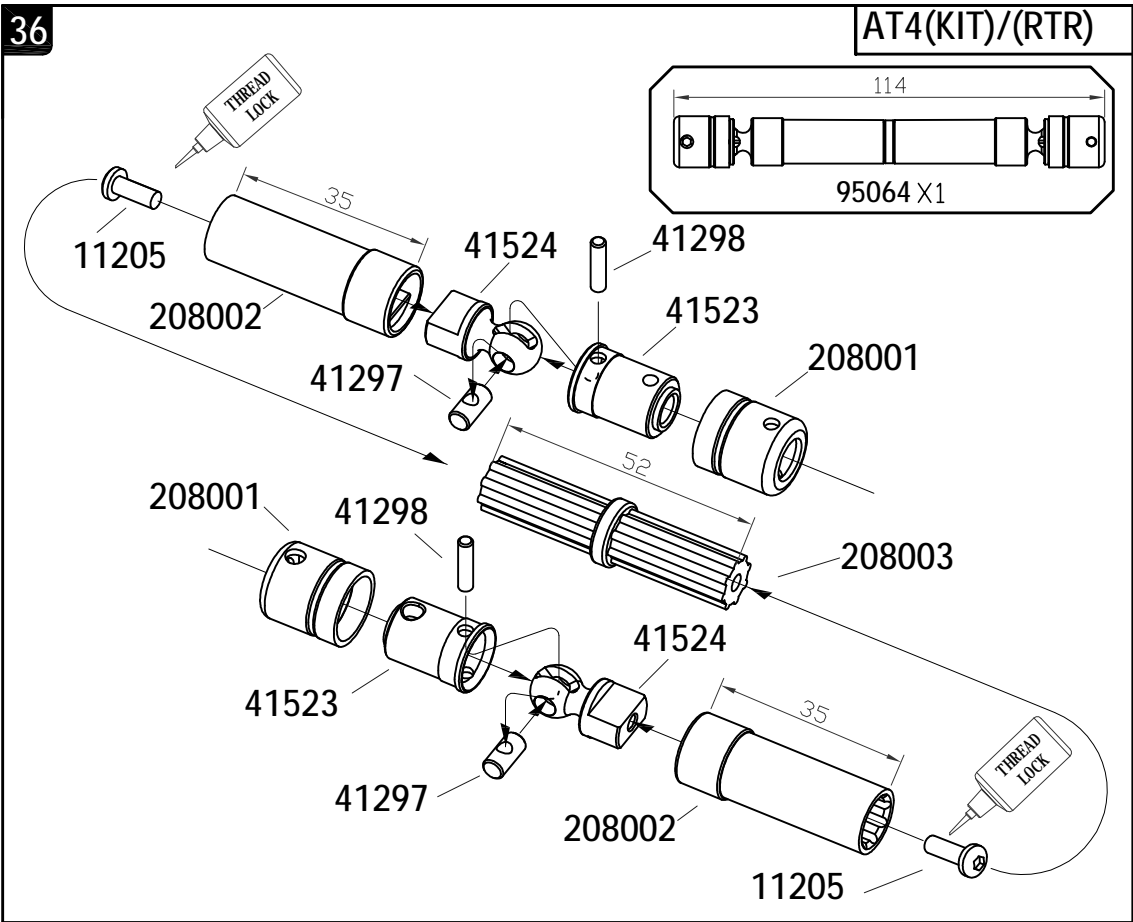

37

AT4(KIT)/(RTR)

BAG(I)

11205  M3x6 X2

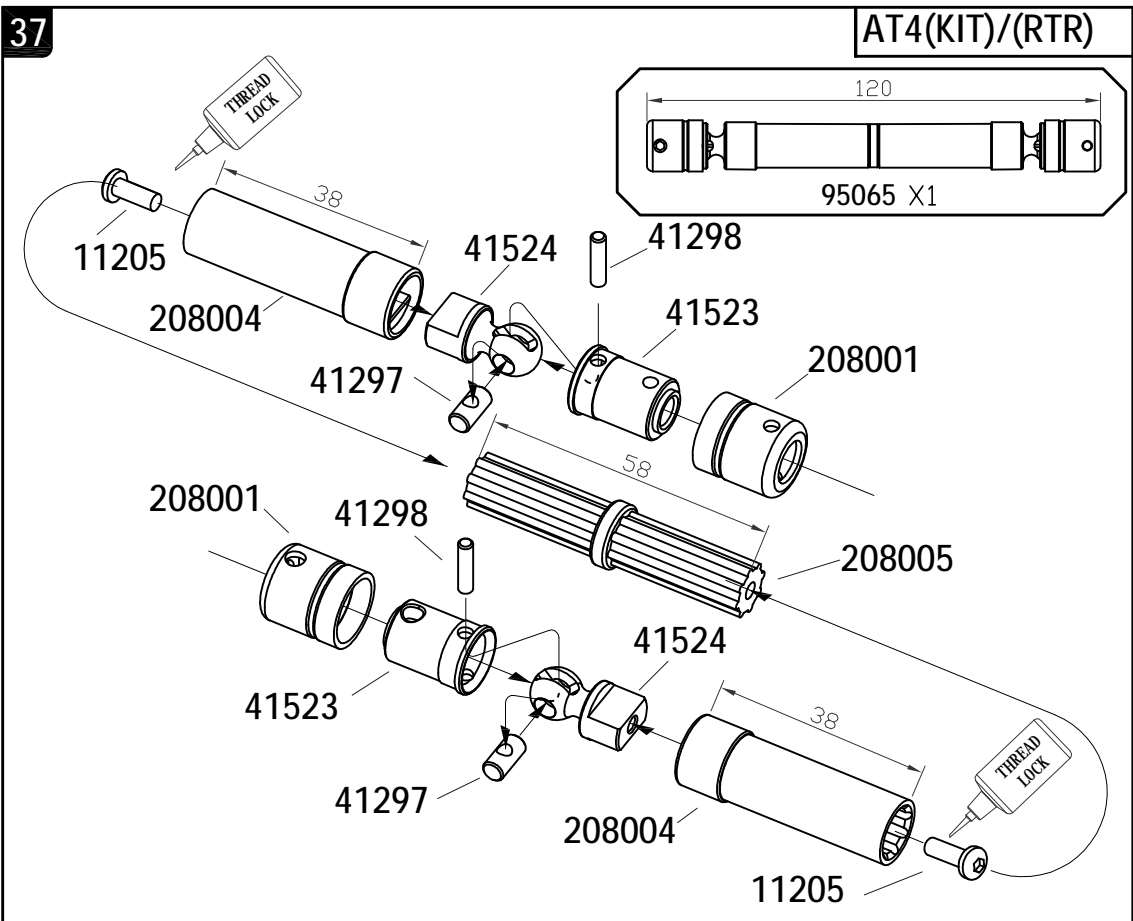

BAG(I)

38

AT4(KIT)/(RTR)



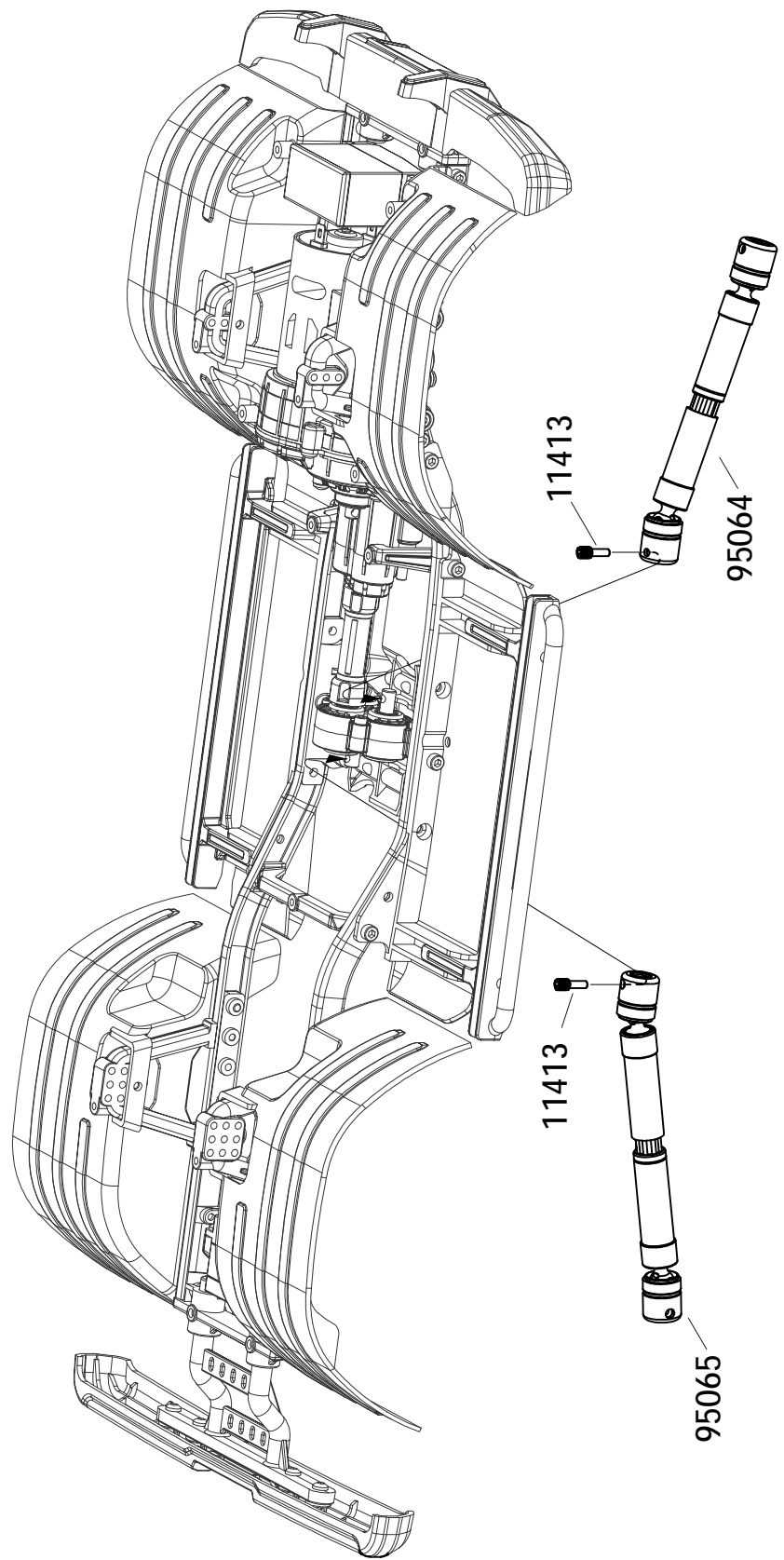

11413 
M4x12x2



BAG(I)

- 11413  M4x12 X1

BAG(V)

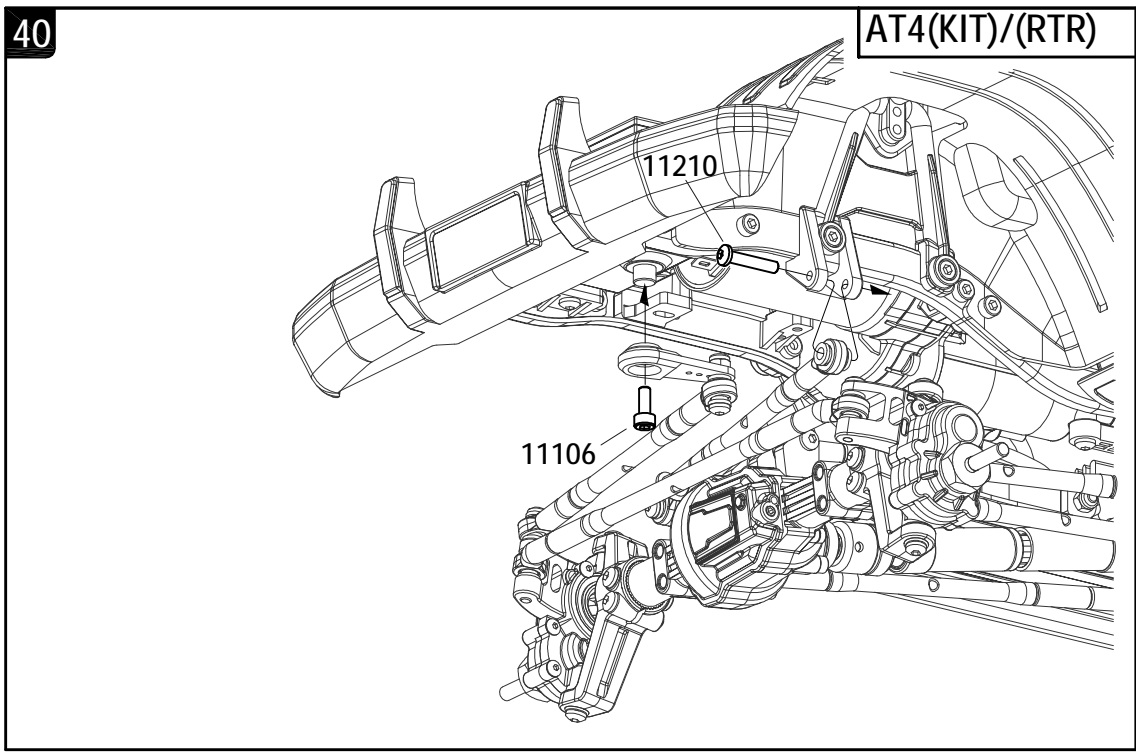
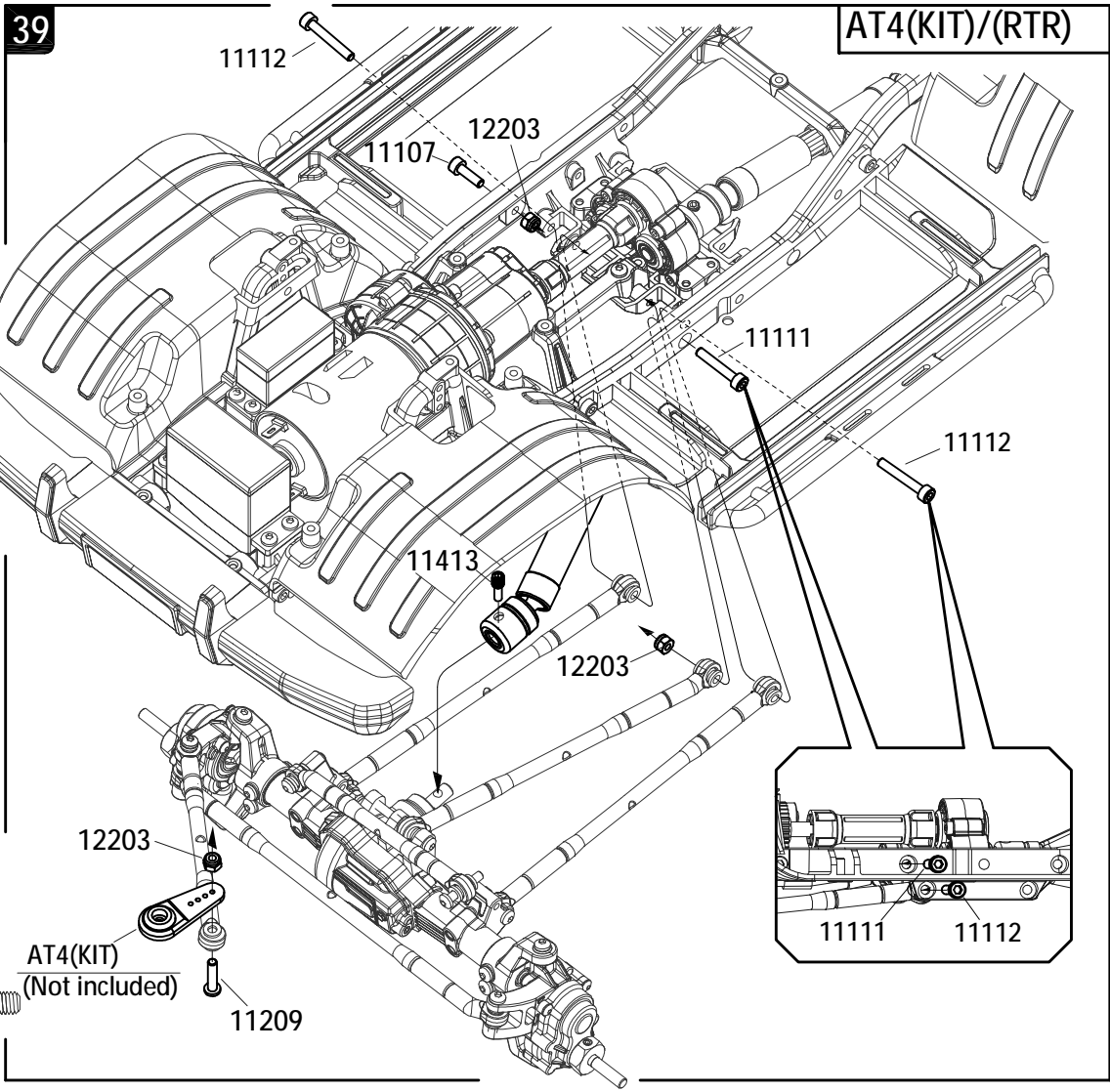

- 11107  M3x10 X1
- 11209  M3x14 X1
- 12203  M3 X3
- 11111  M3x18 X1
- 11112  M3x20 X2



BAG(V)

41

AT4(KIT)/(RTR)

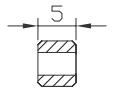

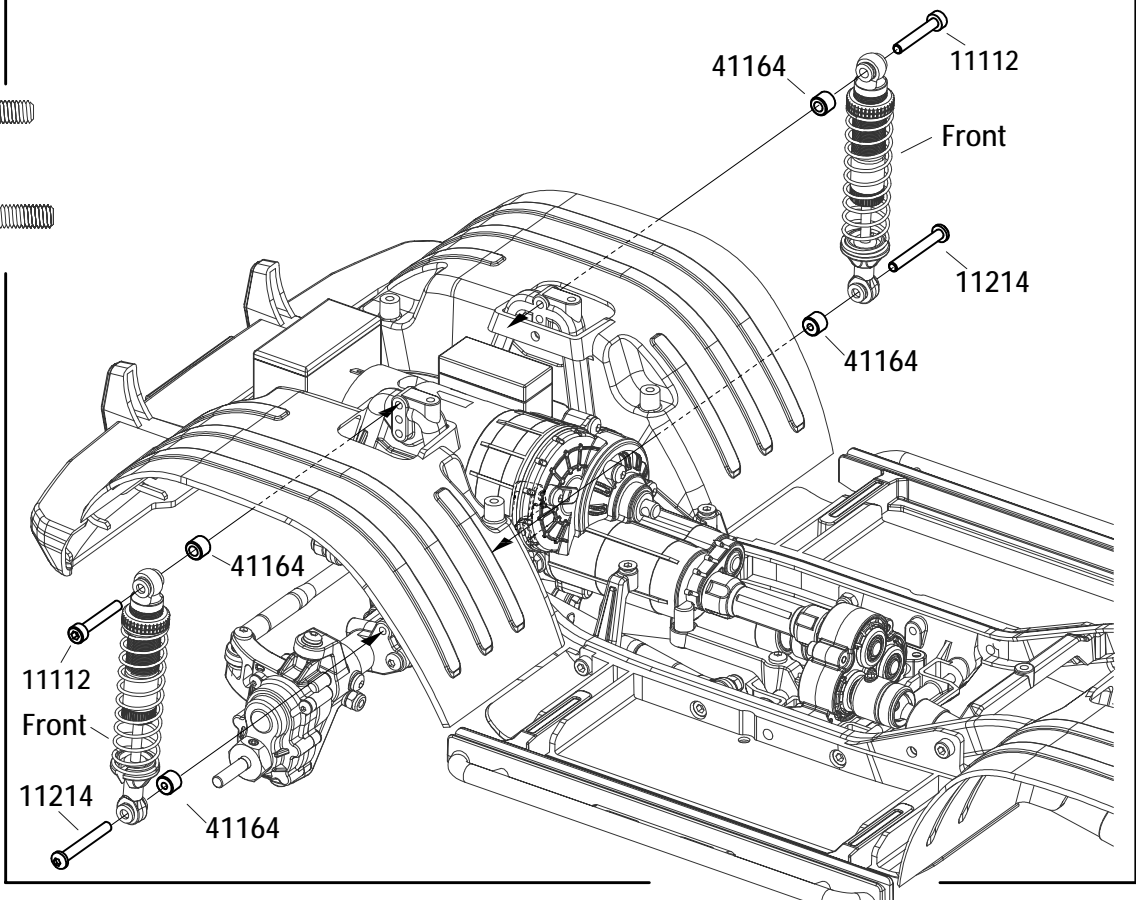
- 11112  M3x20 X2
- 11214  M3x25 X2
-  5
41164 X4



42

AT4(KIT)/(RTR)

- 12203  M3 X2

- 11111  M3x18 X2
- 11112  M3x20 X2

BAG(I)

- 11413  M4x12 X1

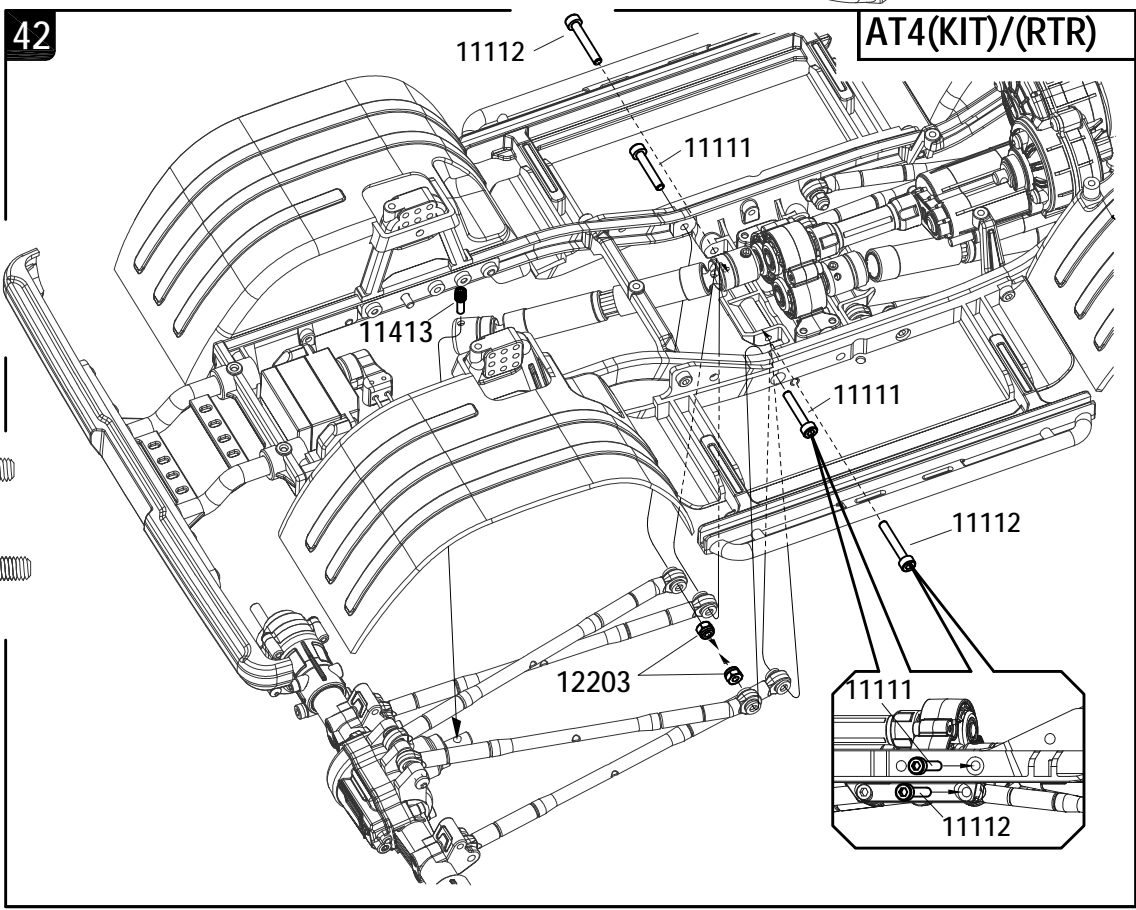

BAG(V)

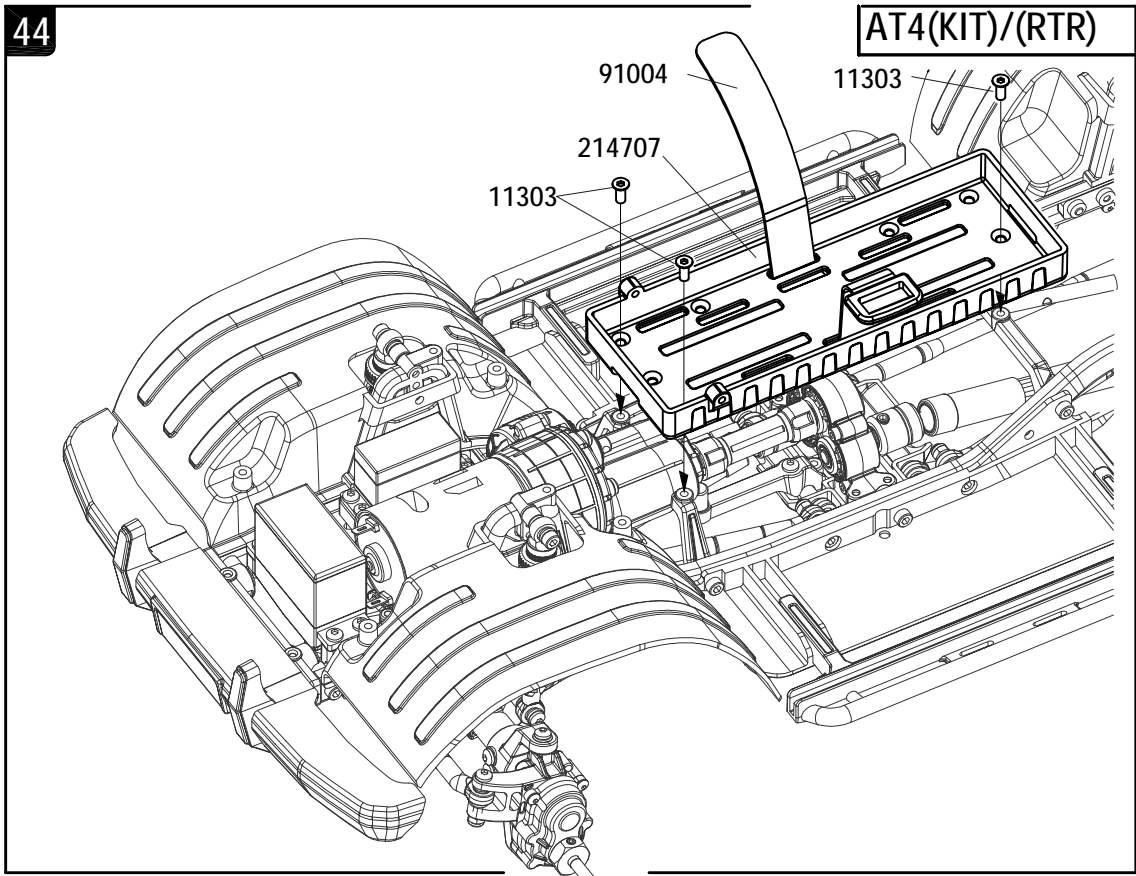
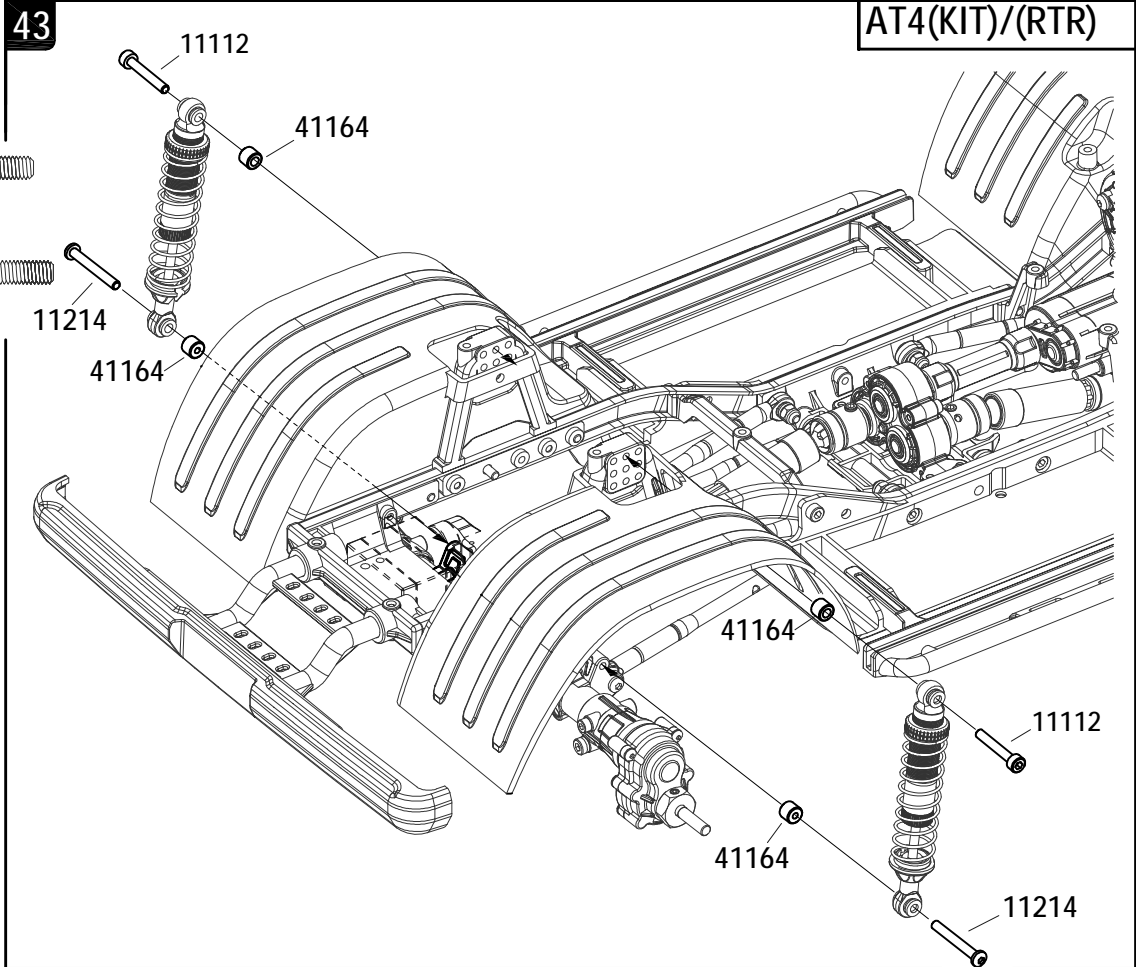

BAG(V)

11207 
M3x10 X4

11209 
M3x14 X4

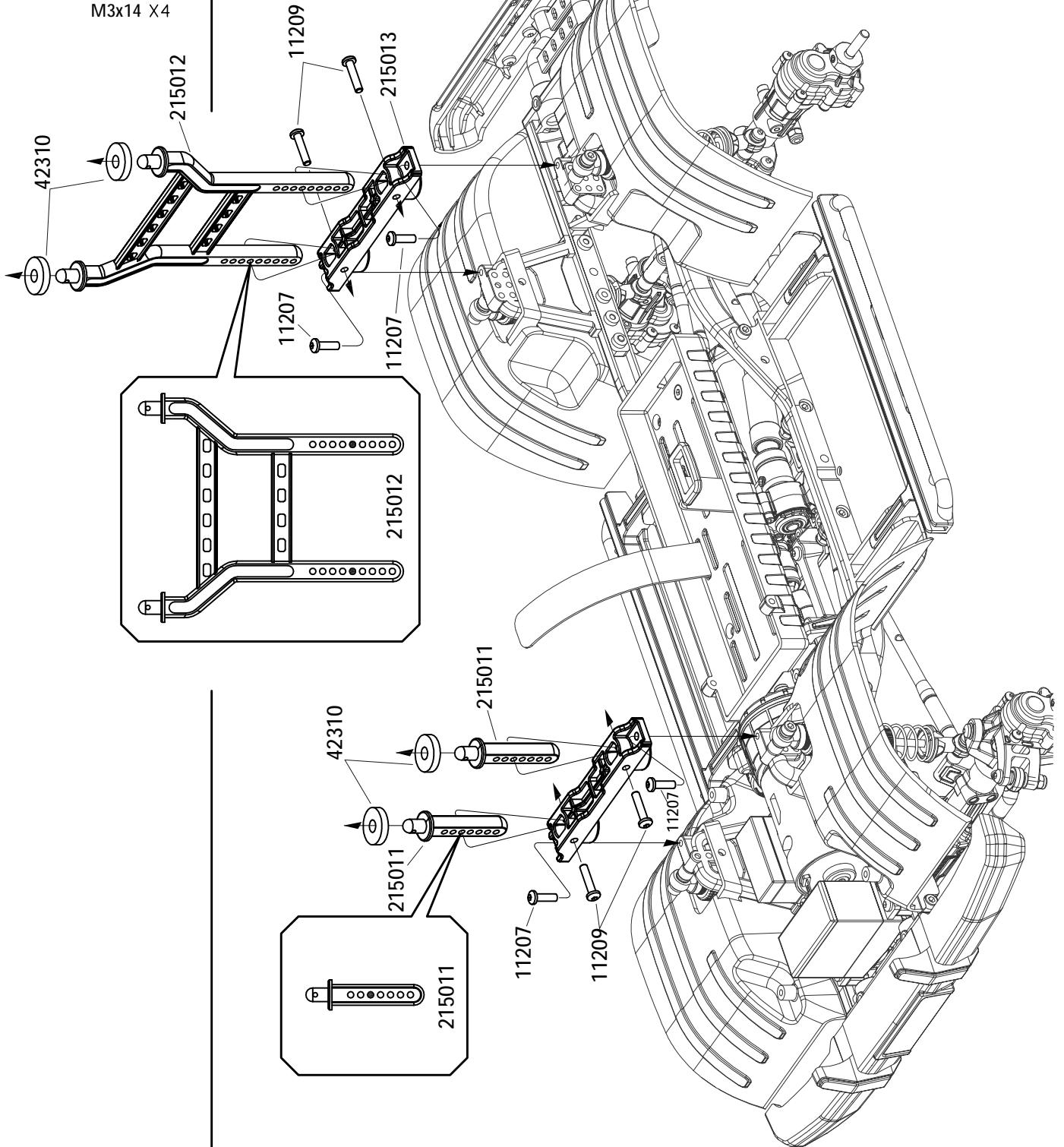

BAG(V)

46

AT4(KIT)/(RTR)

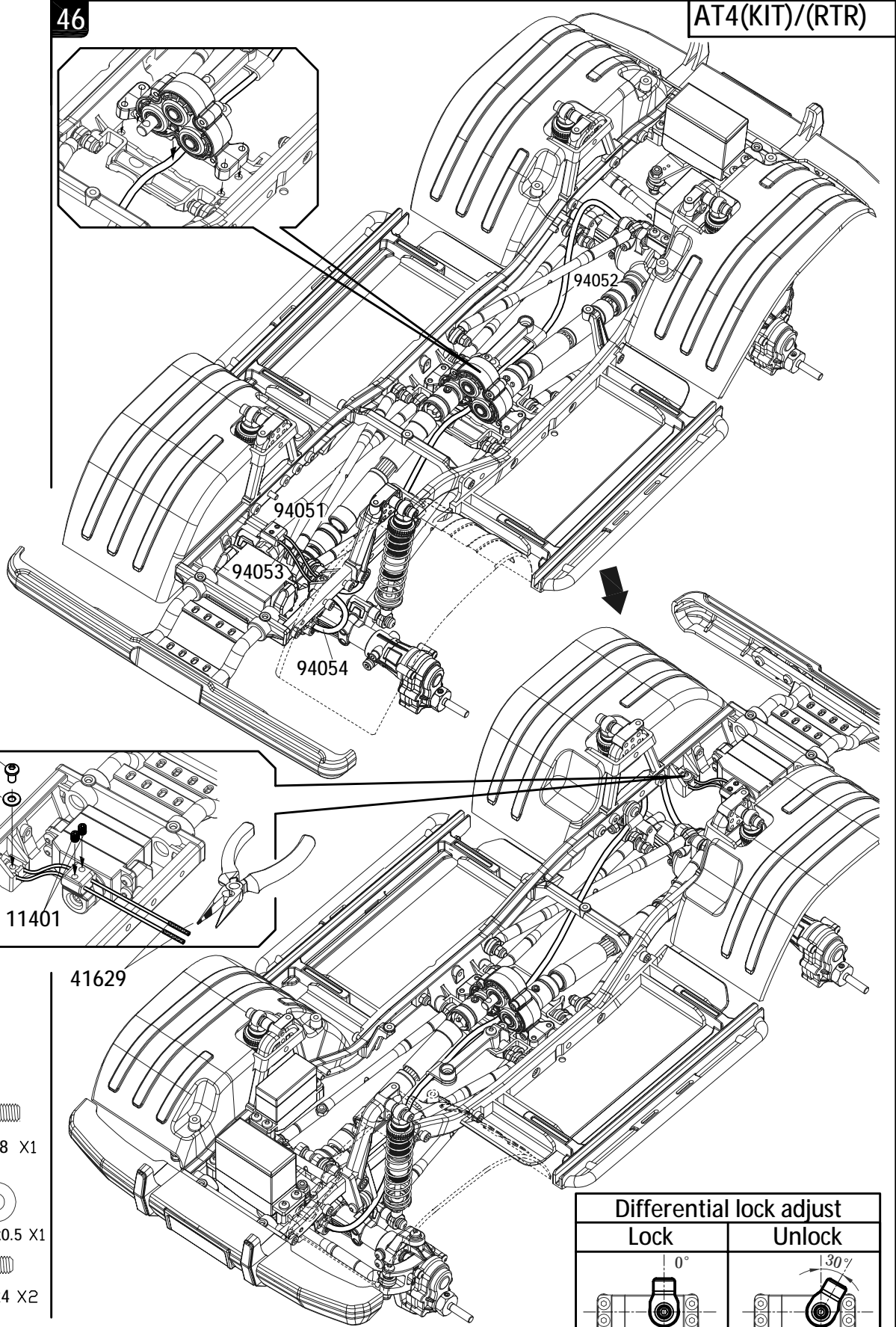

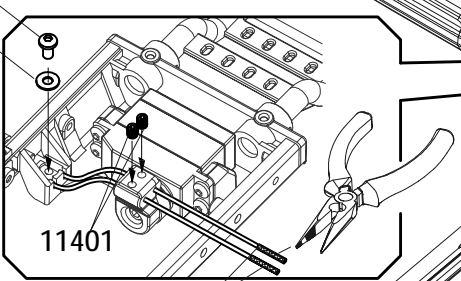

11206
14102



11401

41629

11206  M3x8 X1

14102  Ø3xØ7x0.5 X1

11401  M3x4 X2

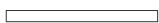
41629  Ø1.5xØ1 x20 X2

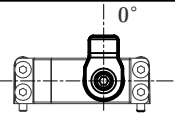
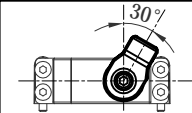
Differential lock adjust	
Lock	Unlock
 0°	 30°
Tips: when the lock is unlocked the cable is pulled out about 4mm	

BAG(A)

- 11125 M2.5x10 X12
- 12105 M2.5 X12

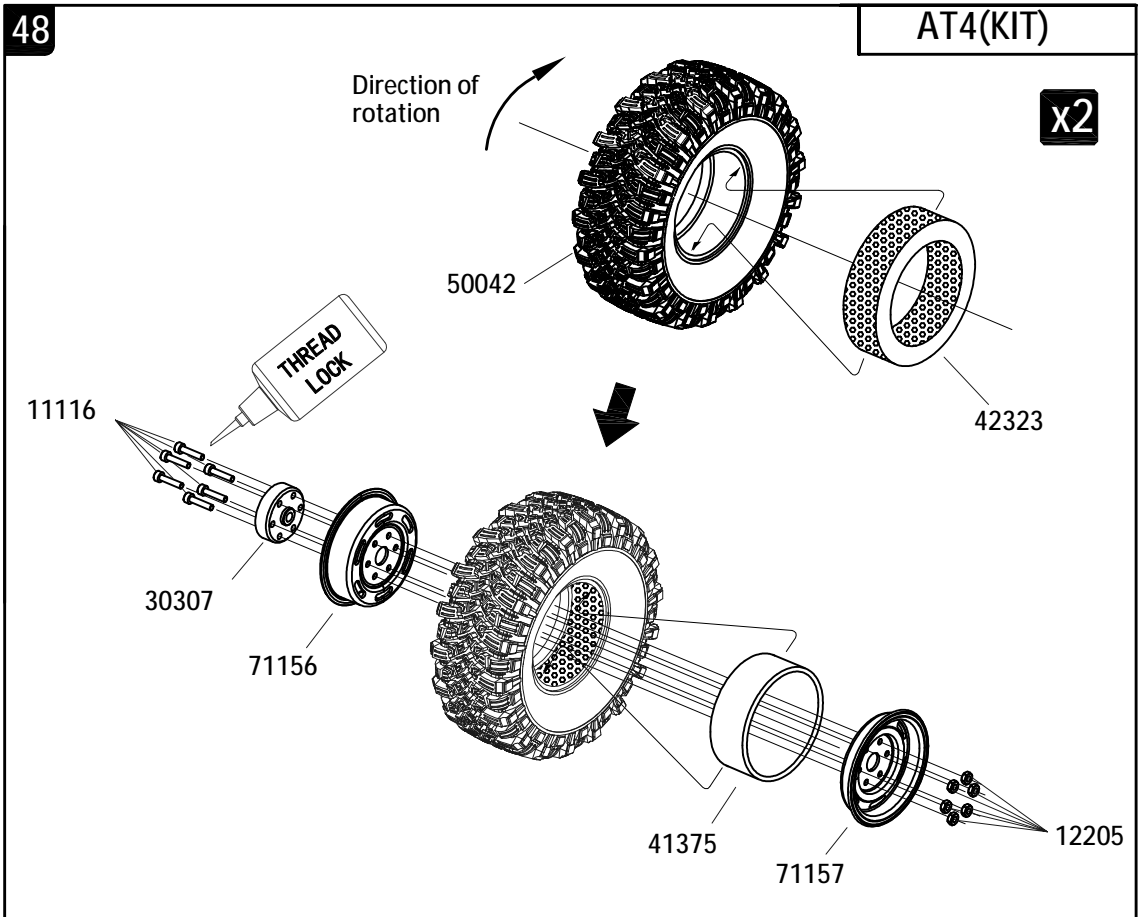
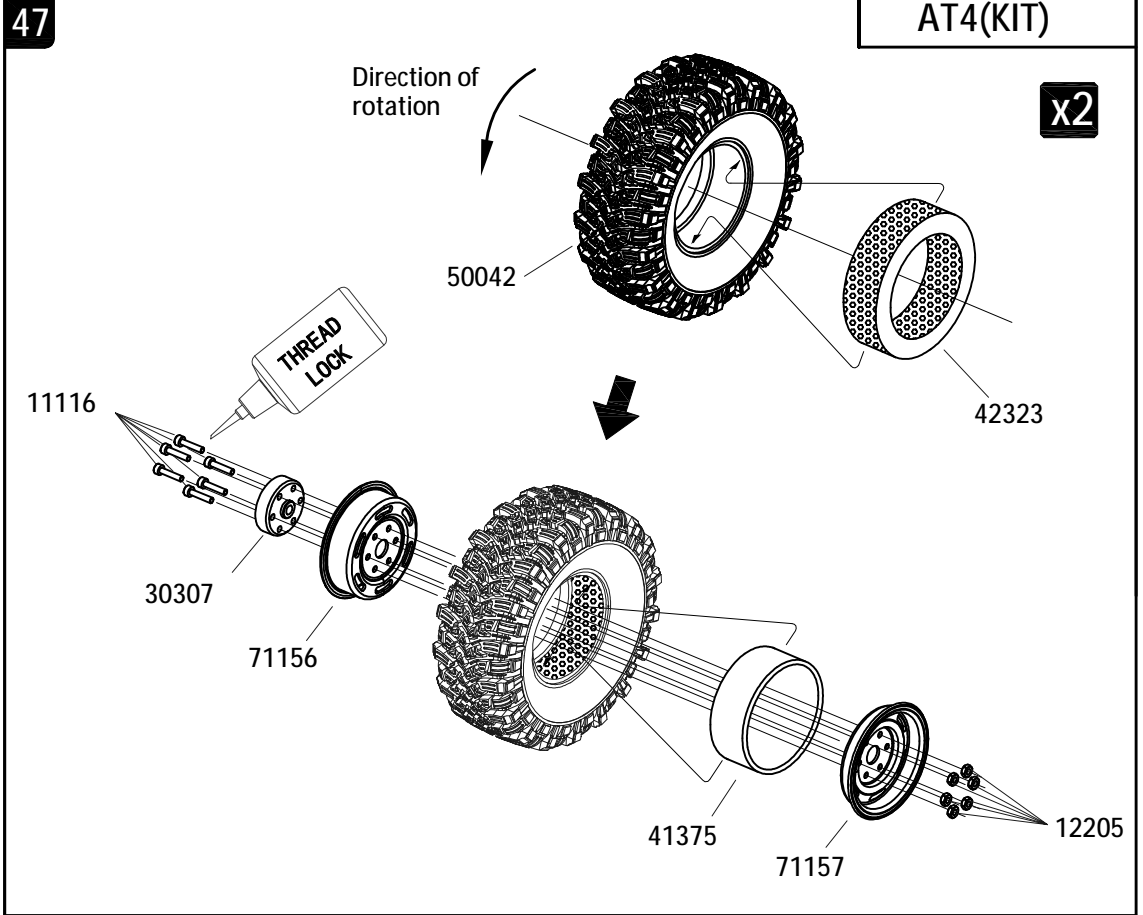

BAG(A)

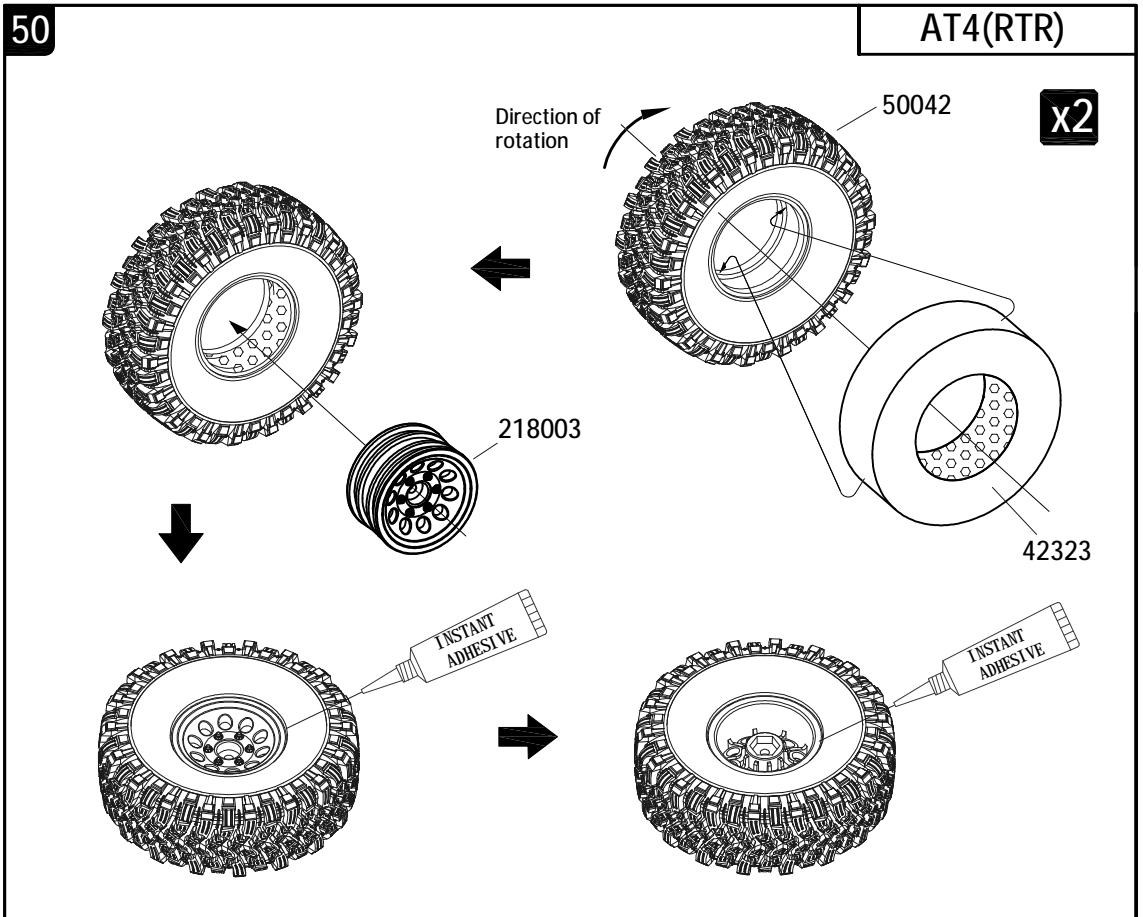
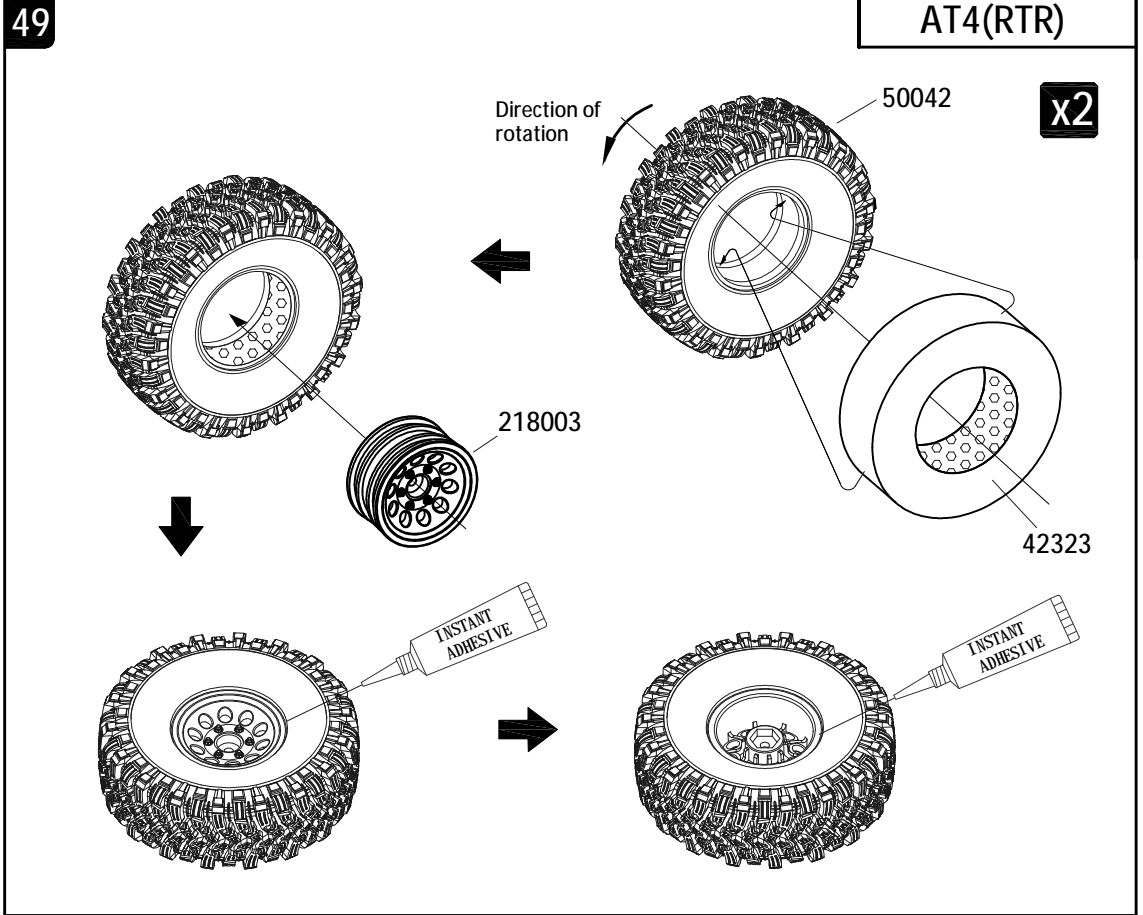

BAG(A)

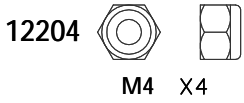

51

AT4(KIT)

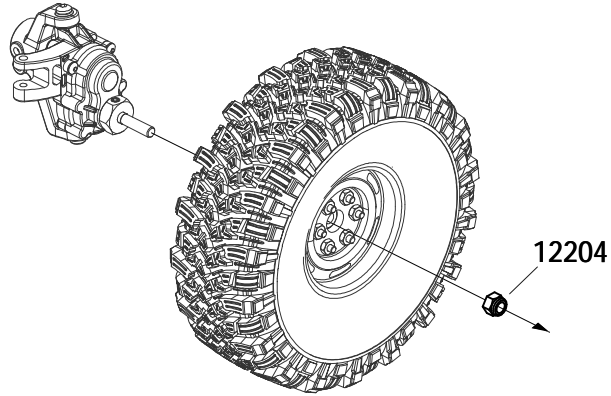

x4

AT4(RTR)

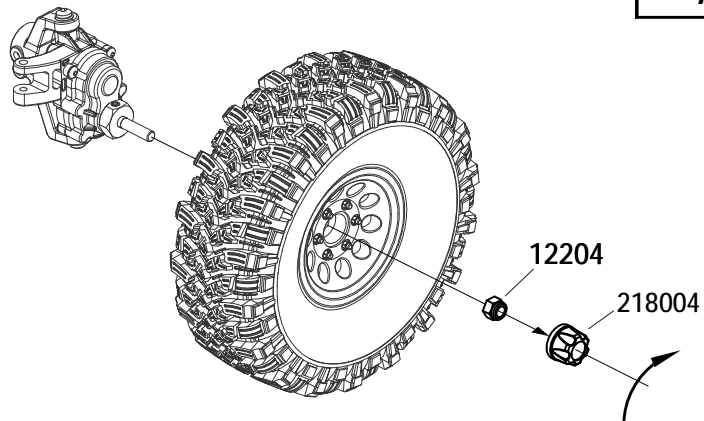

x4

BAG(T)

52

AT4(KIT)/(RTR)

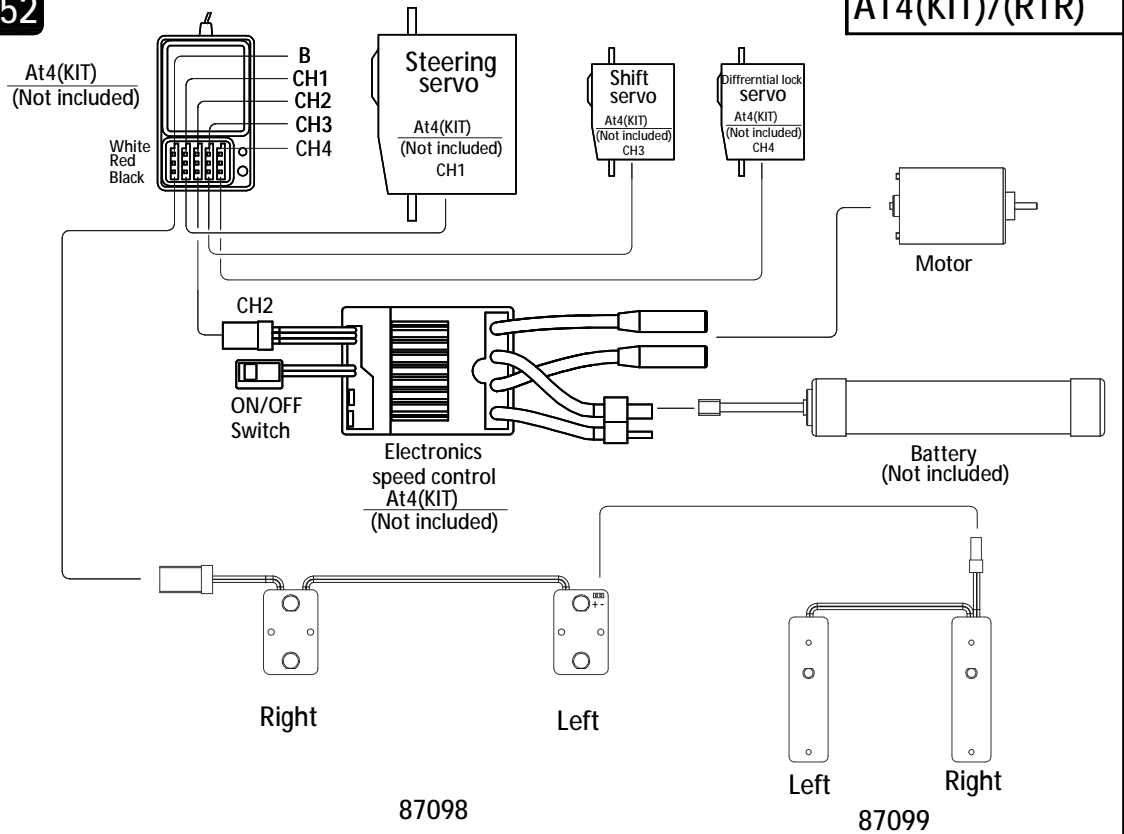

BAG(U)

53

AT4(KIT)

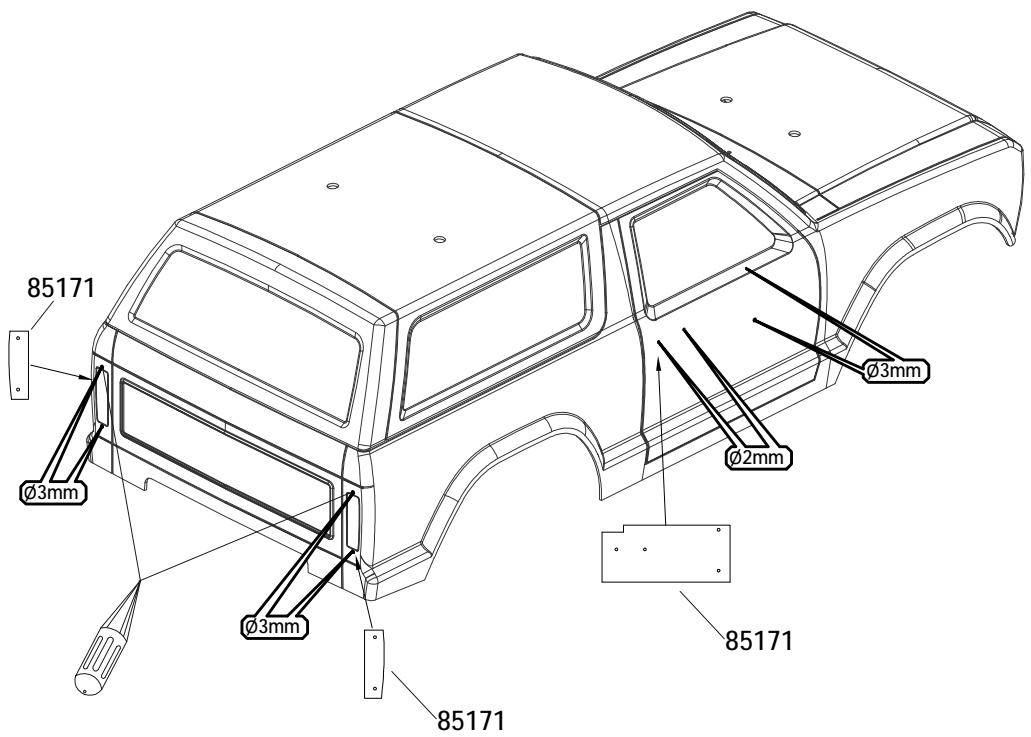
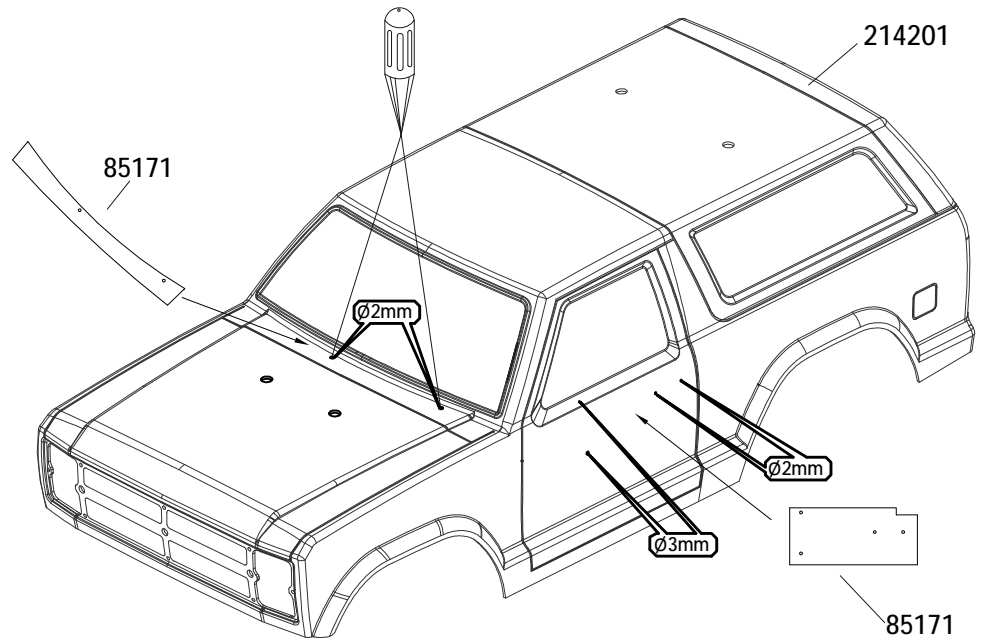

54

AT4(KIT)

Step 1

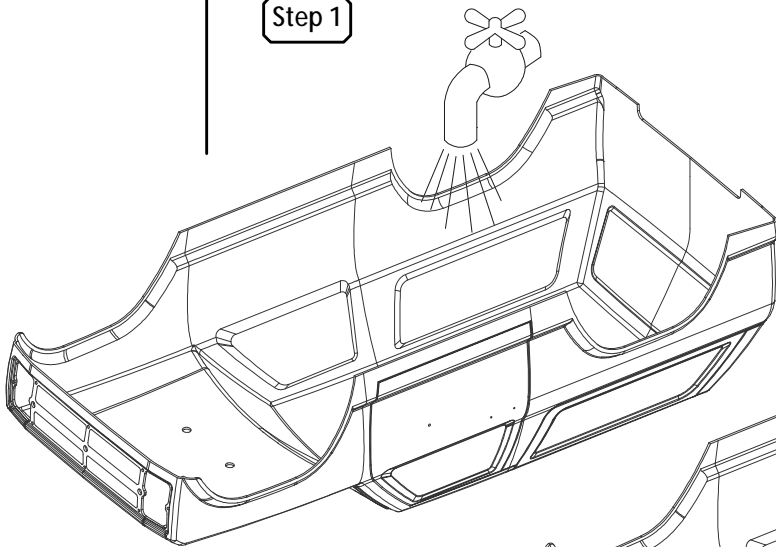

Wash the inside of the body shell with mild detergent, then rinse and dry thoroughly.

Step 2

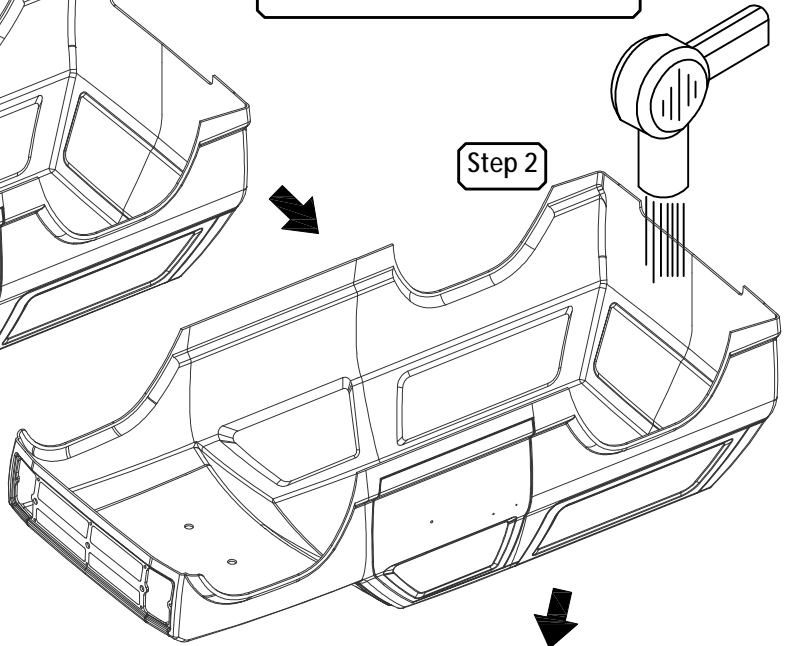

Step 3

Mask the windows on the inside with masking tape.

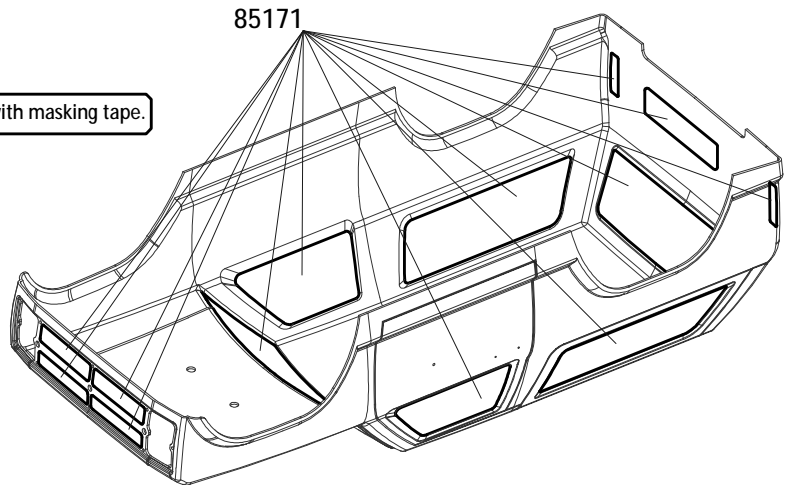

Step 4

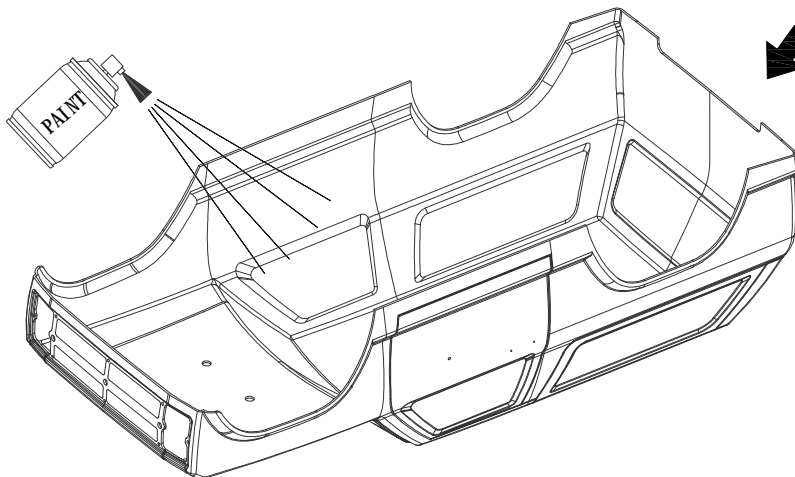

Paint the body with polycarbonate spray paints.

* When the paint is dry, remove the masking.
* When you have finished painting, peel off the external protective films.

BAG(J)

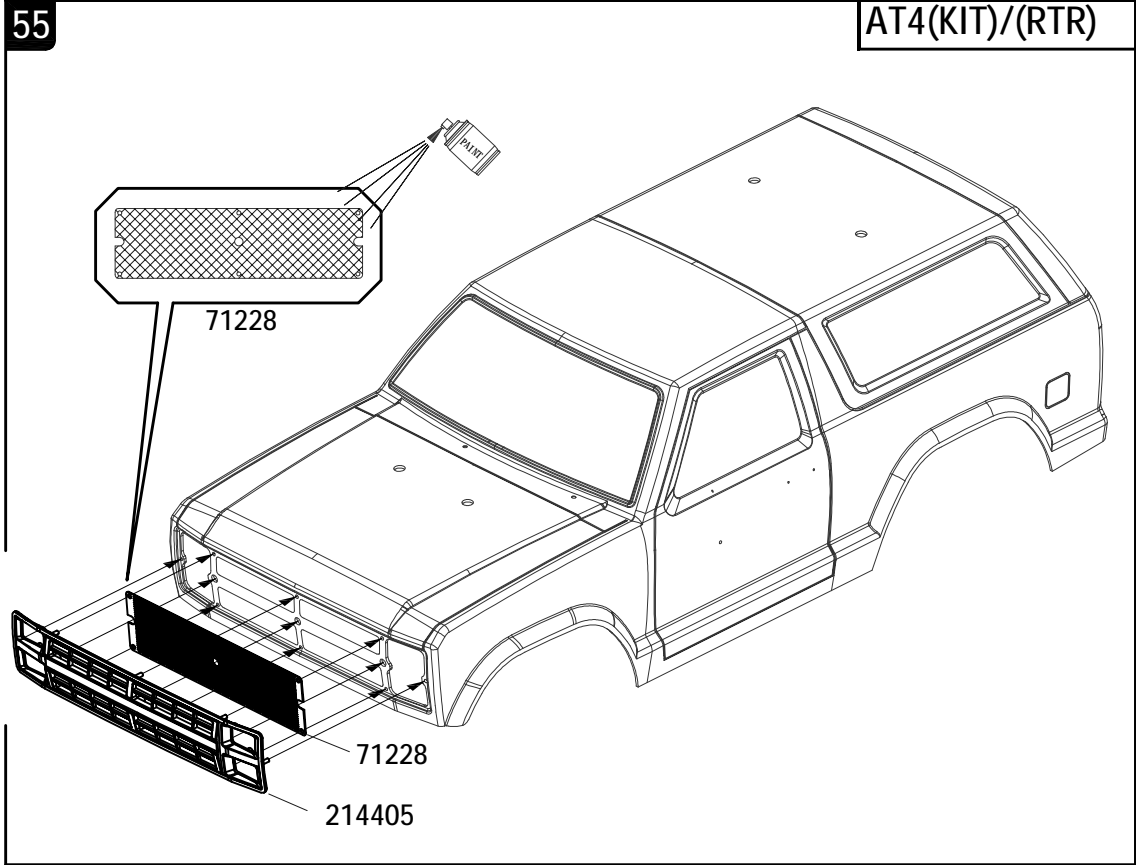

BAG(V)

BAG(S)

BAG(T)

- 11102 M2x6 X6
- 11205 M3x6 X3

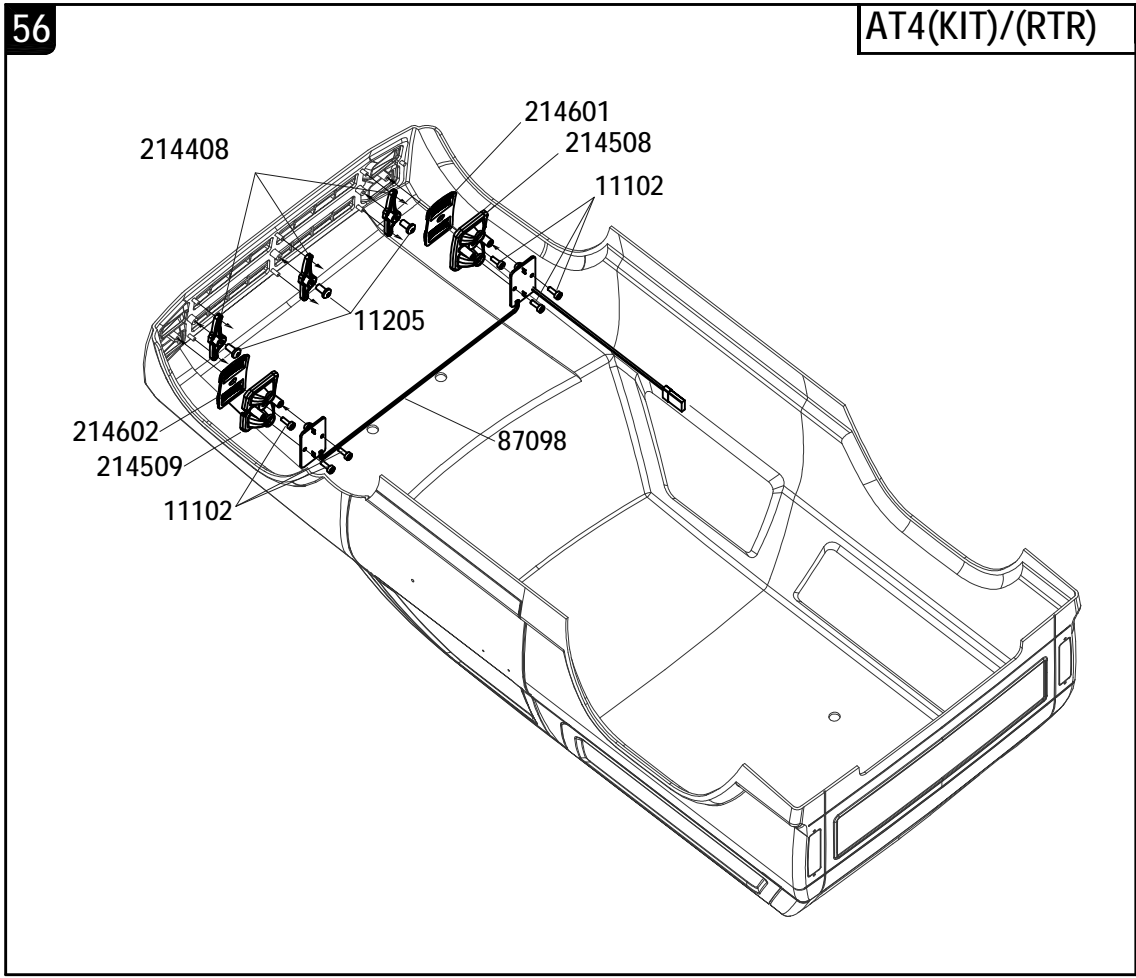

BAG(K)

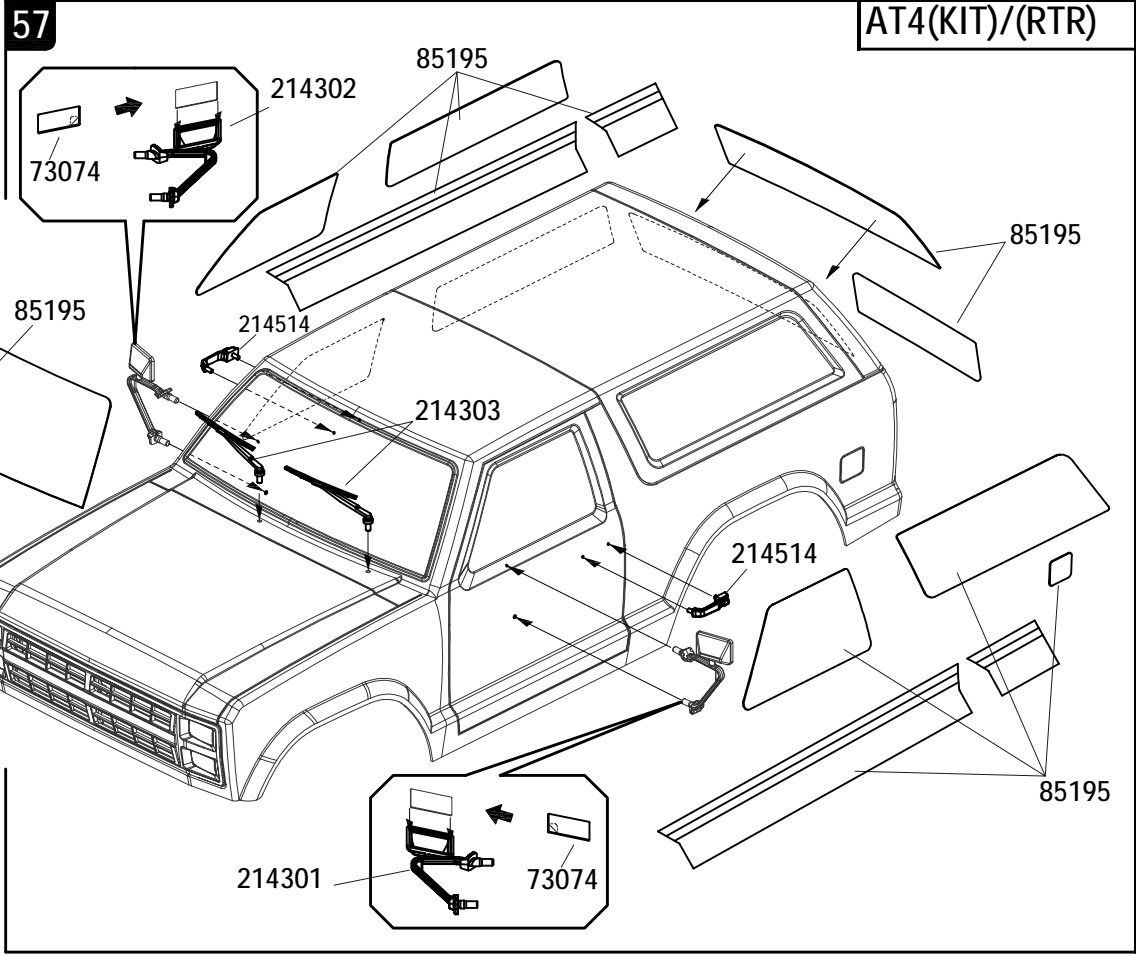

BAG(S)

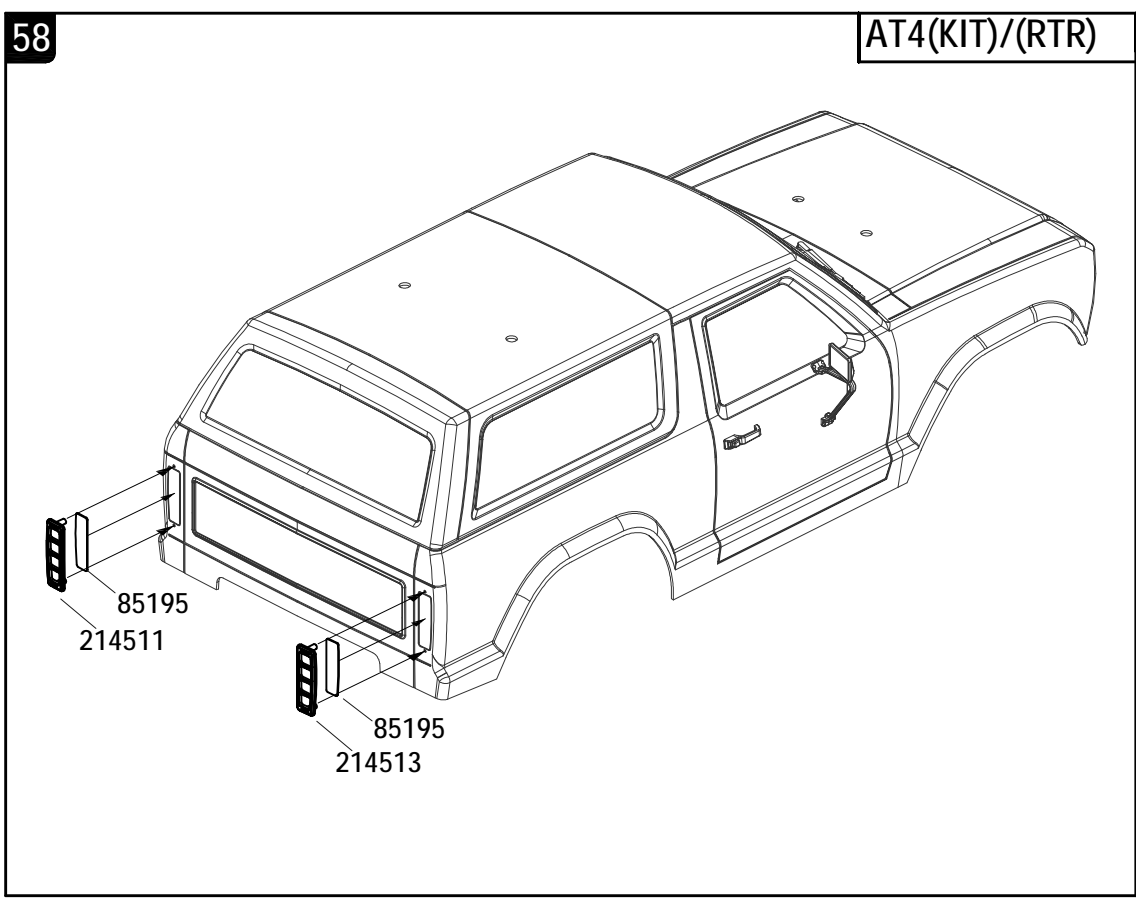



BAG(V)

BAG(T)

59

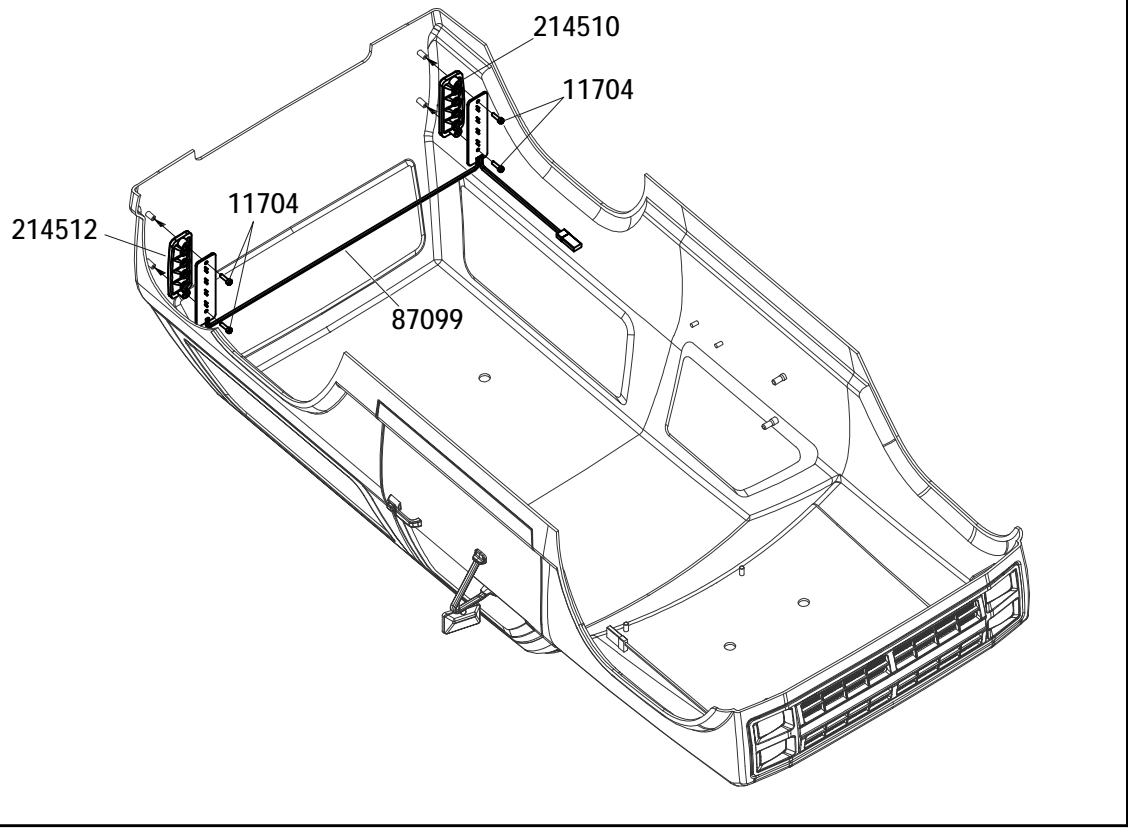
AT4(KIT)/(RTR)



11704 
M1.6x6 X4

60

AT4(KIT)/(RTR)

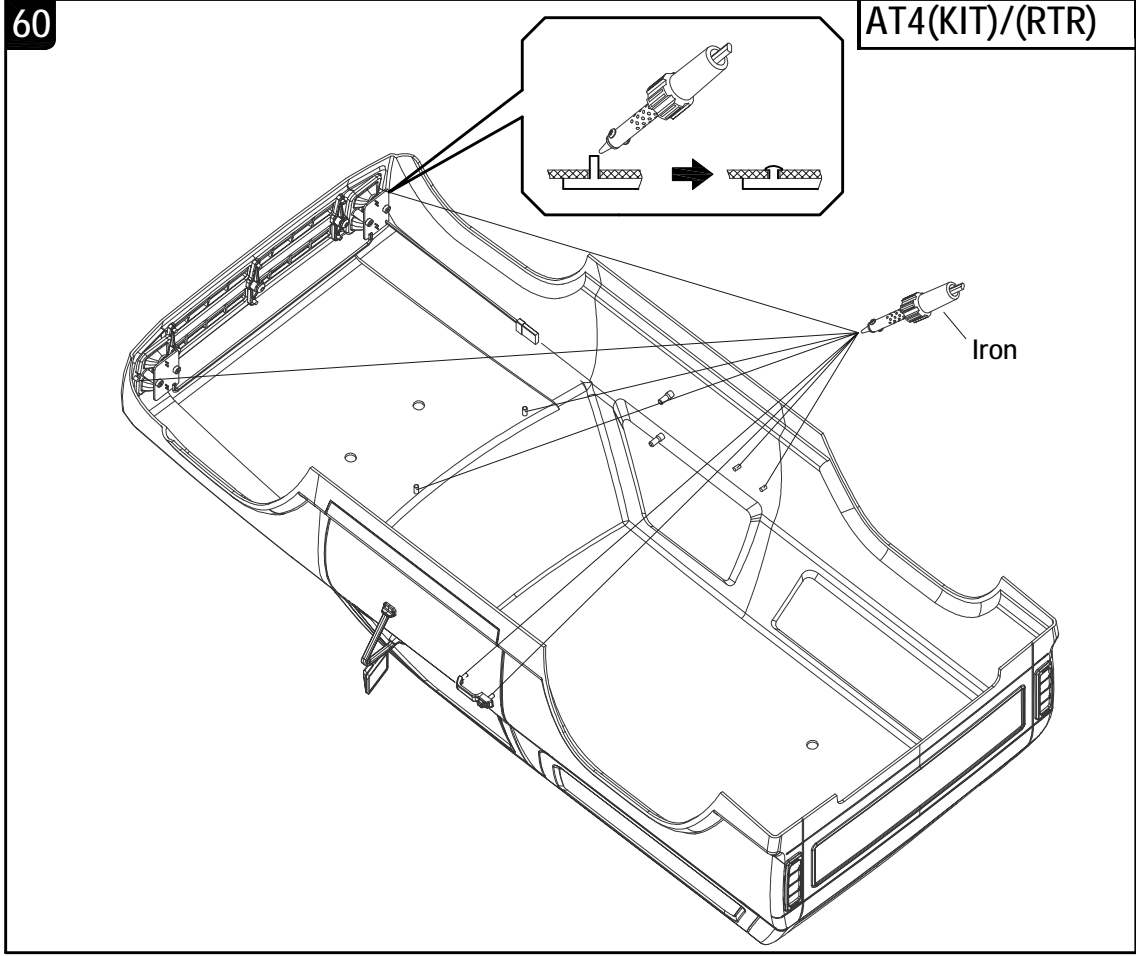

61

AT4(KIT)/(RTR)

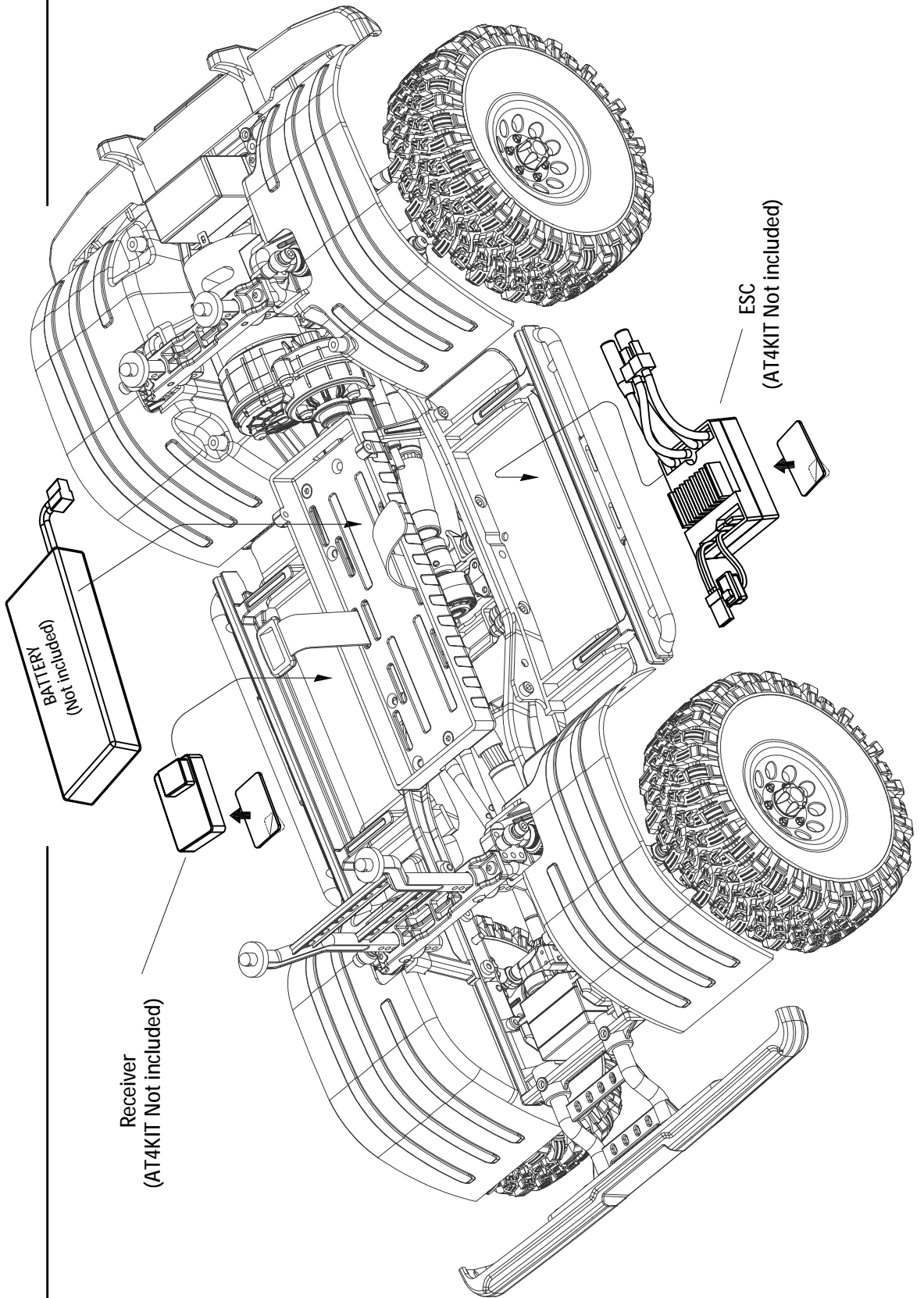

62

AT4(KIT)/(RTR)

94061 x 4

